

Decision

of the Court of First Instance of the Unified Patent Court,

issued on: 12 September 2025

concerning EP 2 223 589

GUIDELINE

S:

1. If the design of a patented product according to the invention is such that its components are assembled in a simple manner at the place of use of the product without the addition of further objects, the offering or supplying of all components already constitutes a direct patent infringement within the meaning of within the meaning of Art. 25(a) UPCA.
2. If a patent-protected product consists of at least two identical, coordinated components which, according to their design, are designed to be assembled into the patent-protected product in accordance with the patent without the addition of further articles, the individual sale of such a component regularly already constitutes direct patent infringement within the meaning of Art. 25(a) UPCA if the possibility of assembly is pointed out or is otherwise obvious.

KEYWORDS:

Delimitation of direct and contributory patent infringement; Offering and supplying components

CLAIMANT

bellissa HAAS GmbH
- Birkenstraße 22 - 88285 - Bodnegg-Rotheidlen - DE

represented by Lenz Bernecker

COMPLAINTS:

1) **Windhager GmbH**
- Industriestraße 2 - 5303 - Thalgau - AT

represented by Matthias Geitz

2) **Johann Windhager** represented by Matthias Geitz
- Industriestraße 2 - 5303 - Thalgau - AT

3) **Stefan Windhager** represented by Matthias Geitz
- Industriestraße 2 - 5303 - Thalgau - AT

PATENT IN DISPUTE:

European Patent No. EP 2 223 589

SPRUCHKÖRPER:

Local Division Mannheim JUDGES:

This decision was issued by the presiding judge Prof. Dr Tochtermann, the legally qualified judge and rapporteur Böttcher, the legally qualified judge Kupecz and the technically qualified judge Tilmann.

LANGUAGE OF PROCEEDINGS: German

SUBJECT: Action for infringement and action for annulment

ORAL NEGOTIATION: 18 July 2025

BRIEF DESCRIPTION OF THE FACTS OF THE CASE:

1. The plaintiff is asserting a claim against the defendants for alleged direct or, in the alternative, indirect infringement of the European patent EP 2 223 589 B1 ("patent in suit") relating to a bed edging with a lockable metal strip. The reference to the grant of the patent-in-suit filed on 11 February 2010, claiming the priority of a German patent application of 25 February 2009, was published on 30 October 2013. The plaintiff is the sole registered proprietor of the patent-in-suit in force in Germany, Austria and Luxembourg (Annexes K 2.1 to K 2.3). For these UPCA contracting member states, the plaintiff is seeking injunctive relief, recall/final removal from the distribution channels, destruction,

information and publication of judgement and seeks a declaration of the obligation to pay damages.

2. Patent claim 1 reads in the German procedural language of the patent in suit:

"Edging for flower beds and grassland areas consisting of at least two sheet metal strips which can be connected to each other at the ends, which are flanged at least on the upper longitudinal side and form connecting ends (2, 3) in the region of their ends, which are inserted into each other in an overlapping manner, one connecting end being formed as a tongue (4), which engages in a receiving slot (16) arranged in the opposite connecting end, **characterised in that** a receiving slot (16) arranged in the beading of one connecting end (3) can be pushed onto the tongue (4) at the other connecting end (2) in a direction perpendicular to the longitudinal extent of the sheet metal strip (6)."

3. Defendant 1 is part of the Windhager group of companies. Its product portfolio includes goods in the garden, insect protection, pest protection and sun protection sectors. Defendants 2 and 3 are its managing directors.
4. Defendant 1 offers bed edging on its website <https://www.windhager.eu/at> under the name "lawn and design edging" (cf. Annexes K3.1 to K3.10).
5. Settlement talks held by the parties before and after the hearing failed. The plaintiff had unsuccessfully warned the defendants jointly at the business address of defendant 1 on 9 November 2022 due to a patent infringement in Germany (see Annex LS 3).

APPLICATIONS OF THE PARTIES

6. The plaintiff applies with the statement of claim:

1. Defendant 1, Defendant 2 and Defendant 3 are ordered to refrain from manufacturing, offering, placing on the market, using or importing or possessing a product with the following characteristics for the aforementioned purposes in the territory of the Contracting Member States Germany, Austria and Luxembourg:

Edging for flower beds and grassland areas consisting of at least two sheet metal strips which can be joined together at the ends, which are flanged at least on the upper longitudinal side and form connecting ends (2, 3) in the region of their ends, which are inserted into one another in an overlapping manner, wherein one connecting end is formed as a tongue (4) which engages in the opposite connecting end in a receiving slot (16) arranged there, characterised in that a receiving slot (16) arranged in the flange of one connecting end (3) is arranged in a direction perpendicular to the longitudinal extent of the sheet metal strip (2, 3).

to the longitudinal extension of the sheet metal strip (6) onto the tongue (4) at the other connecting end (2).

2. In the alternative: Defendant 1, Defendant 2 and Defendant 3 are ordered to refrain from offering or supplying to customers in the territory of the Contracting Member States Germany, Austria and Luxembourg for use in the said territory sheet metal strips which are suitable for use in the following product:

Edging for beds and grassland areas consisting of at least two sheet metal strips which can be joined together at the ends, which are flanged at least on the upper longitudinal side and form connecting ends (2, 3) in the region of their ends, which are inserted into one another in an overlapping manner, one connecting end being designed as a tongue (4), which engages in a receiving slot (16) arranged in the opposite connecting end, characterised in that a receiving slot (16) arranged in the beading of one connecting end (3) can be plugged onto the tongue (4) at the other connecting end (2) in a direction perpendicular to the longitudinal extent of the sheet metal strip (6).

3. The defendant 1, the defendant 2 and the defendant 3 are ordered, at their own expense, to
 - a. to recall the products pursuant to No. 1 and alternatively No. 2 from the distribution channels;
 - b. to permanently remove the products pursuant to No. 1 and, in the alternative, No. 2 from the distribution channels;
 - c. to destroy the products pursuant to No. 1 and, in the alternative, No. 2 or, in the alternative, to remove the patent-infringing properties of the products pursuant to No. 1 and, in the alternative, No. 2.
4. The defendant 1, the defendant 2 and the defendant 3 are ordered to provide the plaintiff with information about
 - a. the origin and distribution channels of the products referred to in paragraph 1 and, in the alternative, paragraph 2 and
 - b. the quantities produced, manufactured, delivered, received or ordered and the prices paid for the products referred to in Clause 1 and, in the alternative, Clause 2; and
 - c. the identity of all third parties involved in the manufacture or distribution of the products referred to in Clause 1 and, in the alternative, Clause 2.
5. It is established that Defendant 1, Defendant 2 and Defendant 3 must compensate the Plaintiff for all damages that it has suffered and will suffer as a result of the acts referred to in Clause 1 and, in the alternative, Clause 2.
6. In the alternative: It is established that Defendant 1, Defendant 2 and Defendant 3 must surrender the winnings.

7. In the further alternative: It is established that defendant 1, defendant 2 and defendant 3 must pay compensation.
 8. The plaintiff is authorised to announce and publish the decision in whole or in part in public media (print media, electronic media, radio, television) at the expense of the defendants.
 9. Defendant 1, Defendant 2 and Defendant 3 are ordered to pay a penalty payment of up to EUR 250,000.00 to the court in the event of any violation of the orders under items 1 to 4.
 10. The first defendant, the second defendant and the third defendant are ordered to pay the costs.
7. With the reply, the plaintiff applies for the infringement action in applications I.1 and I.2:

- I.1. to order the defendants in accordance with claim no. 1 of the statement of claim, in particular if the tongue (4) attaches flexibly to the sheet metal strip as an extension of the sheet metal strip (1);

furthermore, in particular, if the tongue (4) attaches to the sheet metal strip (1) in a bendable manner as an extension of the sheet metal strip (1), with bend-weakened areas being provided on the sheet metal strip (1) in the transition to the tongue (4);

furthermore, in particular, if the tongue (4), as an extension of the sheet metal strip (1), is bendably attached to the sheet metal strip, bending-weakened regions being provided on the sheet metal strip (1) in the transition to the tongue (4), the flanging edge (7, 8, 9) extending over the entire length of the sheet metal strip (1) and being bent up in the region of the opposite connection point (3) and forming a widened flanging edge (9) as a receiving slot (16);

furthermore, in particular, if the tongue (4) is bendably attached to the sheet metal strip (1) as an extension of the sheet metal strip (1), bending-weakened regions being provided on the sheet metal strip (1) in the transition to the tongue (4), the bendability of the tongue (4) being provided by perforations (5) extending in the transverse direction of the wall (6) of the sheet metal strip (1), wherein the flanging edge (7, 8, 9) extends over the entire length of the sheet metal strip (1) and is bent up in the region of the opposite joint (3) and forms a widened flanging edge (9) as a receiving slot (16);

furthermore, in particular, if the tongue (4) is attached to the sheet metal strip (1) in a bendable manner as an extension of the sheet metal strip (1), bending-weakened regions being provided on the sheet metal strip (1) in the transition to the tongue (4), the bendability of the tongue (4) being provided by perforations (5) extending in the transverse direction of the wall (6) of the sheet metal strip (1), wherein the perforations (5) are formed as elongated holes, wherein the flanging edge (7, 8, 9) extends over the entire length of the sheet metal strip (1) and is bent up in the region of the opposite connection point (3) and forms a widened flanging edge (9) as a receiving slot (16);

furthermore, in particular, if the tongue (4) is bendably attached to the sheet metal strip (1) as an extension of the sheet metal strip (1), bending-weakened regions being provided on the sheet metal strip (1) in the transition to the tongue (4), the bendability of the tongue (4) being provided by perforations (5) extending in the transverse direction of the wall (6) of the sheet metal strip (1), the perforations (5) being designed as elongate holes, the flanging edge (7, 8, 9) extends over the entire length of the sheet metal strip (1) and is bent up in the region of the opposite connection point (3) and forms a widened flanged edge (9) as a receiving slot (16), wherein a locking tongue (12) which can be pressed out of the plane of the wall of the sheet metal strip (1) is arranged at one connection end (2, 3) and can be swivelled into a locking opening (11) arranged at the other connection end (2, 3);

- I.2. In the alternative, to order the defendants in accordance with claim no. 2 of the statement of claim,

in particular if the tongue (4) is bendably attached to the sheet metal strip as an extension of the sheet metal strip (1);

furthermore, in particular, if the tongue (4) is attached to the sheet metal strip (1) in a bendable manner as an extension of the sheet metal strip (1), bending-weakened regions being provided on the sheet metal strip (1) at the transition to the tongue (4);

furthermore, in particular, if the tongue (4), as an extension of the sheet metal strip (1), is bendably attached to the sheet metal strip, bending-weakened regions being provided on the sheet metal strip (1) in the transition to the tongue (4), the flanging edge (7, 8, 9) extending over the entire length of the sheet metal strip (1) and being bent up in the region of the opposite connection point (3) and forming a widened flanging edge (9) as a receiving slot (16);

furthermore, in particular, if the tongue (4) is bendably attached to the sheet metal strip (1) as an extension of the sheet metal strip (1), bending-weakened regions being provided on the sheet metal strip (1) in the transition to the tongue (4), the bendability of the tongue (4) being provided by perforations (5) extending in the transverse direction of the wall (6) of the sheet metal strip (1), wherein the flanging edge (7, 8, 9) extends over the entire length of the sheet metal strip (1) and is bent up in the region of the opposite connection point (3) and forms a widened flanging edge (9) as a receiving slot (16);

furthermore, in particular, if the tongue (4) is attached to the sheet metal strip (1) in a bendable manner as an extension of the sheet metal strip (1), bending-weakened regions being provided on the sheet metal strip (1) in the transition to the tongue (4), the bendability of the tongue (4) being provided by perforations (5) extending in the transverse direction of the wall (6) of the sheet metal strip (1), wherein the perforations (5) are formed as elongated holes, wherein the flanging edge (7, 8, 9) extends over the entire length of the sheet metal strip (1) and is bent up in the region of the opposite connection point (3) and forms a widened flanging edge (9) as a receiving slot (16);

furthermore, in particular, if the tongue (4) is bendably attached to the sheet metal strip (1) as an extension of the sheet metal strip (1), wherein the sheet metal strip (1) is bent at the transition to the

the bendability of the tongue (4) is provided by perforations (5) extending in the transverse direction of the wall (6) of the sheet metal strip (1), the perforations (5) being in the form of elongate holes, the flanging edge (7, 8, 9) extending over the entire length of the sheet metal strip (1), and is bent up in the region of the opposite connection point (3) and forms a widened flanged edge (9) as a receiving slot (16), wherein a locking tongue (12) which can be pressed out of the plane of the wall of the sheet metal strip (1) is arranged at one connection end (2, 3) and can be swivelled into a locking opening (11) arranged at the other connection end (2, 3);

8. The "in particular" additions added to the statement of claim relate to the subject-matter of auxiliary requests B1 to B6, with which the plaintiff defends the patent in suit to a limited extent (see below). Claims I.3. to I.5 of the reply refer back to claims I.1 and I.2 and otherwise correspond to claims 3 to 5 of the statement of claim without any substantive change; claims I.6 to I.10 of the reply refer to claims 6 to 10 of the statement of claim. For this reason, they are not reproduced. Upon request, the plaintiff stated in a written submission dated 7 July 2025 (main workflow) that claim no. I.2 is also submitted for decision in the alternative in the event that the court should consider certain forms of infringement not to be covered by an otherwise successful claim no. I.1.
9. The defendants, who expressly object to the amendment of the claims in the reply as a precautionary measure, request the following:
 - I. The action is dismissed.
 - II. Orders the applicant to pay the costs.
10. Defendant 1 has brought an action for annulment (CC_65106/2024, UPC_CFI_778/2024). In this respect, it requests:
 - I. European Patent No. EP 2 223 589 B1 be declared invalid in its entirety.
 - II. The plaintiff shall bear the costs of the counterclaim proceedings.
11. Upon request, the defendant re 1 informed in a written submission dated 7 July 2025 (substitute workflow App_32774/2025) that the nullity counterclaim relates to the EPC contracting states Germany, Austria and Luxembourg.
12. The applicant, who has filed a request for amendment of the patent (App_13144/2025), requests with regard to the nullity counterclaim

II.1. Dismiss the counterclaim;

II.2. in the alternative, to dismiss the counterclaim in part and to maintain the patent in suit in accordance with one of the auxiliary requests 1 to 6 in Annexes B1 to B6.

13. With regard to the request for amendment of the patent, the defendant re 1,

in the alternative, that European Patent No. EP 2 223 589 B1 also be declared invalid to the extent of auxiliary requests B1 to B6.

FACTUAL AND LEGAL ISSUES IN DISPUTE

14. The parties dispute the following points in particular.

INFRINGEMENT DISCUSSION

PATENT-INFRINGING PROPERTIES OF THE COMPOSITE BED EDGING

15. The plaintiff is of the opinion that edgings consisting of lawn and design edges of defendant 1 realise claim 1 of the patent in suit in accordance with the literal meaning.

16. In the opinion of the defendant, however, these bed edgings do not have a tongue in accordance with the claim (feature 2.3.2). Rather, the connecting ends are clearly set off from the metal strip. The connecting end must be identical to the tongue ("designed as a tongue"). The element claimed as a tongue was not a connecting end, but merely an extension. The connecting ends themselves, namely the ends of the lateral main edges, therefore did not overlap in the contested embodiment (feature 2.3.1), but lay end to end. In the absence of a tongue, this also does not engage in a receiving slot (feature 2.3.4).

PATENT INFRINGING ACTS

17. The plaintiff alleges patent infringing acts in Austria and Germany with reference to the Austrian website of defendant 1 (Exhibits K3.1 to K3.10), which is also aimed at business customers in Germany (see inserts in the reply, p. 10 et seq.), and a test purchase from a third-party company in Germany (Exhibits K4, K5). Furthermore, it alleges patent infringements in Luxembourg, whereby the pre-trial negotiations regarding a licence for Luxembourg in addition to Germany, Austria and Switzerland at least illustrate a corresponding willingness to supply.

18. The defendants criticise the lack of evidence of infringing acts. The test purchase is not attributable to the first defendant. It is not apparent from the internet presence of the first defendant, even insofar as excerpts are shown in the reply, that all the features of claim 1 have been realised. The contrary is disputed. The excerpts submitted with the complaint were dated 5 March 2024, while the alleged test purchase was only made on 20 June 2024 and thus more than three months ago.

REFERENCE TO PLEADINGS

19. For further details, please refer to the exchanged pleadings and attachments.

COUNTERCLAIM FOR ANNULMENT

20. Defendant 1 bases its revocation counterclaim on the following grounds for revocation pursuant to Art. 138 EPC in conjunction with Art. 65(2) UPCA:

- lack of novelty (Art. 138(1)(a) in conjunction with Art. Art. 54(1), (2) EPC);
- lack of inventive step (Art. 138(1)(a) in conjunction with Art. 56 EPC). Art. 56 EPC).

21. It considers the subject-matter of the patent in suit not to be new in comparison with DE 1 871 426 U (DE'426; Annex LS 6) and US 2006/0150480 A1 (US'480; Annex LS 11), and furthermore not to be based on an inventive step based on DE 299 01 263 U1 (DE'263; Annex LS 7), alternatively in connection with further prior art.

22. For further details, reference is made to the exchanged written submissions and annexes.

REASONS FOR THE DECISION

23. The admissible action is well-founded, the admissible counterclaim is unfounded.

A. ADMISSIBILITY

International jurisdiction of the UPC

24. The UPC's international jurisdiction for the infringement action follows from Art. 31 UPCA, Art. 4 (1), Art. 63 (1) Brussels Ia Regulation. Defendant 1 has at least its main administration and principal place of business in Austria. In the absence of any evidence to the contrary, it must be assumed that Defendants 2 and 3, as their managing directors, also have their place of

also have their place of residence in Austria as the state of the head office of defendant 1.

25. In addition, the UPC's international jurisdiction for all defendants also arises from Art. 31 UPCA, Art. 7(2) Brussels Ia Regulation. The Plaintiff alleges acts of infringement by Defendant 1, for which Defendants 2 and 3 are allegedly jointly responsible as their managing directors, in Germany, Luxembourg and Austria and thus in UPC Contracting Member States. Whether these acts of infringement, which have not been alleged out of the blue, actually exist and whether the defendants 2 and 3 are jointly responsible for them is a question of the merits.
26. In any event, international jurisdiction follows from Art. 71a(1), (2)(a), Art. 71b(1), Art. 26(1) Brussels Ia Regulation, because the defendants have not objected to international jurisdiction, especially not with the first submission on the merits in the statement of defence.
27. International jurisdiction for the revocation counterclaim pursuant to Art. 32(1)(e) UPCA follows from Art. 31 UPCA in conjunction with Art. 24(4), 71a(2)(a), 71b(1) Brussels Ia.

Local jurisdiction of the Local Division Mannheim

28. The local jurisdiction of the Local Division Mannheim results from Art. 33(1)(a) UPCA. The plaintiff alleges infringement in Germany. Reference is made to the above statements on international jurisdiction.
29. The jurisdiction of the Local Division Mannheim, which is based on its competence, also extends to acts of infringement in other UPCA contracting member states, namely Luxembourg and Austria. This is confirmed by the provisions of Art. 33(2) UPCA. Moreover, the UPC's internal jurisdiction follows from R. 19.7 RP, since the defendants did not raise an objection under R. 19 RP. This would apply even if the internal jurisdiction of the local and regional divisions were determined by the Brussels Ia Regulation, as the defendants have not objected to jurisdiction as provided for in Art. 26(1) Brussels Ia Regulation. The local jurisdiction extends to the action for revocation (Art. 33(3)(a) UPCA).

Admissibility of the amendment of the claims with the reply in infringement proceedings

30. The admissibility of the amendment of the claims, to which the defendants objected, with the reply in the infringement proceedings already follows from the fact that the "in particular" additions included correspond to those versions of the patent in suit which the plaintiff is defending in the alternative with its application to amend the patent. The plaintiff thus recognises that, if necessary, it will also base its action on one of these versions. The admissible (alternative) defence of the patent in suit in one or more limited versions in the case in dispute means that the infringement action may also be based on these limited versions (cf. Local Chamber Mannheim, decision of 2 April 2025, UPC_CFI_359/2023 para. 28 - Fuji ./ Kodak and others; decision of 6 June 2025, UPC_CFI_471/2023 para. 50 - DISH and others ./ Aylo and others).

B. INTERPRETATION OF THE PATENT IN SUIT

31. According to the generic term of patent claim 1, the invention relates to an edging for beds and grassland areas.

32. The patent in suit regards it as known to produce bed edgings from sheet metal strips, whereby several elongated sheet metal strips are joined together. It is known to provide the longitudinal sides of the sheet metal strips with beading on at least one side in order to protect the sheet metal strip against tearing and to avoid a sharp edge (para. [0002]).

33. However, according to the description of the patent in suit, such bed edgings, which consist of strips of sheet metal joined together, are generally not bendable and therefore cannot be bent into round bed edgings (para. [0003]). In the case of longitudinally connectable sheet metal strips which, however, can only be connected in a straight line, it is known according to the patent specification in suit to design the connection in such a way that the respective end face of the sheet metal strip is designed as a tongue which is pushed into an associated pocket-shaped receptacle on the end face of the opposite sheet metal strip (para. [0004]). According to the description in the patent application, this presupposes that the metal strips are inserted against each other precisely in the direction of their longitudinal extension and joined together. According to the patent specification, however, this type of assembly has the disadvantage that the sheet metal strips can only be assembled by inserting them into one another, which means that in the case of relatively large bed edgings with a radius of e.g. 2 m, three or more strips of sheet metal have to be inserted into one another.

four metal strips must be inserted into each other and then installed in the ground as a bed edging (para. [0005]). The patent specification in suit considers this to be a difficult handling of such a bed edging and an unsuitable assembly (para. [0006]).

34. According to the patent in suit, US 2006/0150480 A1 shows an edging system for e.g. lawn edges in the horticultural sector. The system is designed to be pluggable and has male and female plug-in connection ends for this purpose. However, the embodiments described there have the disadvantage that they can only be inserted into the ground when plugged together. The design of the plug-in connections does not allow the individual panels to be installed in the ground (para. [0007]).
35. The patent in suit describes it as the task underlying the invention to further form a bed edging from a lockable sheet metal strip of the type mentioned at the beginning in such a way that the sheet metal strips can be successively fixed or anchored in the ground and thus the sheet metal strips can be successively assembled without the need to first assemble all the sheet metal strips together and then install them in the ground (para. [0008]).
36. In order to solve this problem, the patent in suit in claim 1 protects an edging for beds and grassland areas, the features of which can be organised as follows (different organisation of the parties in square brackets):

Edging for beds and grassland areas [M1.1]

1. The edging consists of at least two metal strips; [M1.2 - Part 1]
2. The two sheet metal strips
 - 2.1. can be joined together at the ends; [M1.2 - Part 2]
 - 2.2. have upper longitudinal sides and [are] flanged at least on these sides; [M1.3]
 - 2.3. have end faces and form connecting ends in the area of these; [M1.4]
 - 2.3.1. the connecting ends are inserted into each other in an overlapping manner; [M1.5]
 - 2.3.2. one connecting end is designed as a tongue; [M1.6]
 - 2.3.3. a receiving slot is arranged at the opposite connecting end; [M1.7 - part 1]
 - 2.3.4. the tongue engages in the receiving slot; [M1.7 - part 2]
 - 2.3.5. the receiving slot is arranged in the flange of the [one] connecting end; [M1.8]

2.3.6. the receiving slot can be pushed onto the tongue at the other end of the connection in a direction perpendicular to the longitudinal extension of the sheet metal strip. [M1.9]

37. Some features require explanation.

38. The skilled person not expressly defined by the parties is a mechanical engineer with a degree from a university of applied sciences and several years of professional experience, in particular in the field of sheet metal constructions in gardening and landscaping. This includes experience in the design of multi-part sheet metal structures, including the shaping of the associated components and solutions for connecting them.

39. From the specialist's point of view, the characteristics are as follows: Characteristic

2.1, 2.3 - End face

40. The end faces of the sheet metal strips are formed by narrow end faces of the sheet metal strip and not by the upper long side of the respective sheet metal strip.

41. This is already clear to the person skilled in the art from the wording of the claim. The claim speaks of sheet metal strips, by which the person skilled in the art, in particular through the word component "strip", usually imagines narrow objects extending in a longitudinal direction, which have longitudinal sides and narrow end sides. The skilled person finds this initial understanding of the shape of the sheet metal strip confirmed in the claim itself by the reference to an upper longitudinal side. The skilled person finds further confirmation of this initial understanding in the reference to a longitudinal extension of one of the sheet metal strips in the claim. Finally, the reference to end faces is also a confirmation of this understanding; the person skilled in the art usually sees these as the narrow end faces of an elongate strip.

42. However, the skilled person does not stop at such a view based solely on the wording of the patent claim. According to Art. 69 (1) sentence 2 EPC, the description and the drawings must be used to interpret the patent claim (cf: UPC_CoA_335/2023, order of 26 February 2024, GRUR-RS 2024, 2829, para. 73 - 79 - method of proof). Based on this, if the skilled person takes a look at the description of the patent in suit, they will recognise in para.

The dimensions of a sheet metal strip that can be used in the enclosure according to the invention. There it is proposed to use as the sheet metal strip in particular a galvanised sheet metal with a thickness of e.g. 0.65mm, which has a height of e.g. 130mm, the sheet metal strip having a length of e.g. 1.20m (corresponds to 1,200mm). The skilled person sees this as confirmation of his understanding from the claim that the invention envisages sheet metal strips which have a considerably greater longitudinal extent than width (height) (in the proposal from paragraph [0018] approx. 10 times longer than wide (high)). The skilled person finds further confirmation of this understanding in Fig. 1 and Fig. 9 of the patent in suit, which show different embodiments of the invention and, in turn, sheet metal strips which have a considerably greater longitudinal extent than width (height) and which, in addition to longitudinal sides, also have narrow end sides which correspond to the skilled person's understanding of an "end face". Fig. 1 and Fig. 9 are reproduced below.

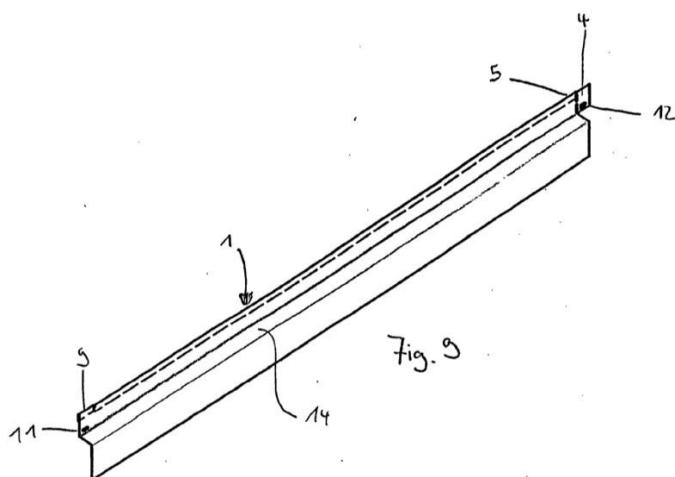
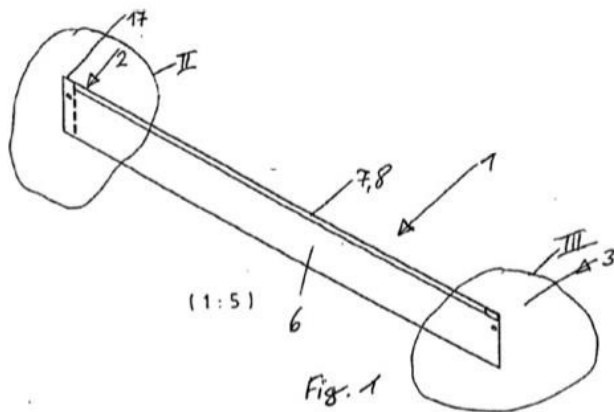

Features 1, 2.3.1 - at least two metal strips; connecting ends inserted into each other in an overlapping manner

43. The claim is directed to the edging in the state in which the connecting ends of the two metal strips *are* inserted into one another in an overlapping manner (feature 2.3.1) and the tongue *engages* in the receiving slot (feature 2.3.4). The sheet metal strips whose connecting ends are *not* inserted into each other in an overlapping manner and in which the tongue *does not* engage in the receiving slot, for example a loose collection of sheet metal strips, are not a suitable edging.
44. According to feature 1, the claim is directed to an edging for beds and grassland areas consisting of at least two metal strips and thus, according to the understanding of the person skilled in the art, to the end product, but at least to a product in which the connecting ends of the two metal strips *are* inserted into one another in a mutually overlapping manner and the tongue *engages* in the receiving slot. This follows directly from features 2.3.1 and 2.3.4.
45. By using the term "*connectable*" in feature 2.1, the claim refers to the suitability to connect the two metal strips to each other at the end faces and therefore does not require in this feature that the metal strips *are* connected. However, since feature 2.1 also does not require that the sheet metal strips *are not* connected, the pure suitability specification of feature 2.1 is not suitable for relativising the specific condition specification of features 2.3.1 ("are inserted into each other") and 2.3.4 ("engages"). The same applies to the suitability information in feature 2.3.6, according to which the receiving slot *can be pushed onto* the tongue at the other end of the connection in a direction perpendicular to the longitudinal extension of the metal strip. Rather, these features specify an additional property, namely that the elements referred to - irrespective of the assembled state - are designed to be "connectable" or "attachable". This ensures that the protected article fulfils the above-mentioned task, namely that the sheet metal strips can be fixed or anchored in the ground one after the other and thus the sheet metal strips can be installed one after the other without it being necessary to first install all the sheet metal strips and then install the finished bed edging in the ground (para. [0008]).
46. According to their wording and function, connection ends are the end areas on the front sides that contribute to the connection of two metal strips. The degree of

The claim does not contain any special specification regarding the overlap of the ends of two connected metal strips. An overlap is therefore sufficient to ensure that the sheet metal strips are joined in such a way that they are suitable for use as bed edging.

Feature 2.3.2 - Tongue

47. With regard to the shape of one end of the connection, claim 1 provides, but at the same time also allows it to be sufficient that this end of the connection is designed as a tongue (feature 2.3.2) and that the tongue and the receiving slot arranged at the other end of the connection are at least matched to each other in such a way that the tongue engages in the receiving slot (feature 2.3.4). The claim does not make any further specification with regard to the shape of the connecting end formed by the tongue and, in particular, does not specify that the tongue continues the wall of the metal strip at one connecting end in the same width (height). Such a specification is only found in sub-claim 2. Claim 1 also covers shapes in which the tongue is narrower than the width (height) of the sheet metal strip.
48. The description of a tongue referred to by the defendant (statement of defence, para. 26) in paragraph [0029] of the patent in suit, according to which the tongue *consists* of the wall of the metal strip, relates solely to a possible embodiment of the invention which has not been included in claim 1 and to which the claim is not defined; only sub-claim 2 deals with the possibility that the tongue continues the wall of the metal strip at a connecting end in the same width.
49. The skilled person will find this understanding confirmed in the embodiments shown in Fig. 1 and Fig. 9. For example, Fig. 1 shows an embodiment in which the tongue continues the wall of the sheet metal strip at one end of the joint with the same width, while Fig. 9 shows an embodiment in which the tongue 12 has a significantly smaller width (height) than the end face of the wall of the sheet metal strip.
50. Although claim 1 specifies that the sheet metal strips form connecting ends in the region of the end faces, at the same time it does not exclude the possibility that further elements, for example a locking mechanism, are formed in the region of one end face in addition to a connecting end formed as a tongue. Since claim 1 does not specify that each end face has exactly one connecting end, the other elements can also participate in the connection.

51. Nor does claim 1 exclude a multi-element tongue. The only decisive factor is that the tongue, irrespective of its further shape, fulfils the intended technical function of engaging in the receiving slot and thereby being able to ensure the connection. Since claim 1 does not impose any special requirements on the extent of the engagement, the tongue in particular does not have to be completely picked up by the receiving slot. Rather, engagement is sufficient to ensure a connection via the interaction between the tongue and the receiving slot.

Feature 2.2 - Flanging

52. The sheet metal strips are flanged at least on the upper longitudinal side (feature 2.2). In addition, the sheet metal strip is flanged in the area of the connecting end where the receiving slot is located. This is clear to the person skilled in the art from feature 2.3.5, according to which the receiving slot is arranged in the beading of the connecting end. In order for the receiving slot to be arranged in the flange of the connection end, the connection end must have a flange.

53. The claim does not require flanging in the area of the connecting end, which is formed as a tongue according to feature 2.3.2, but does not exclude it either. A person skilled in the art will only find an exclusion of flanging in the area of the connecting end formed by the tongue in sub-claim 3, where it is specified that the flanging edge of the sheet metal strip extends over the entire length, but only until shortly before an end-side release and thus forms the adjoining tongue. Claim 1 does not contain a comparable specification.

54. Since claim 1 is a product claim, the way in which the beading was produced in the manufacturing process is, as usual, irrelevant. It is therefore sufficient that the beading has those properties which arise during the beading process. As can be seen from the wording and the figures, flanging requires the formation of a fold or a change in direction compared to the surface of the sheet. It also follows from paragraph [0002] and the fact that nothing is to be changed in this respect according to the invention that a flange must be suitable for protecting the sheet metal strip against tearing and avoid a sharp edge. There are no indications that the application of a specific manufacturing process is particularly important.

Feature 2.3.6 - Can be mounted in a vertical direction

55. The receiving slot can be slipped onto the tongue at the other end of the connection in a direction perpendicular to the longitudinal extension of the metal strip (feature 2.3.6). The wording of the claim does not expressly specify the perpendicular direction. However, it follows from the function according to the invention of enabling a further sheet metal strip to be mounted on a sheet metal strip already in the ground by attaching it from above and pressing it downwards in a direction perpendicular to the longitudinal extent of the sheet metal strip (see paragraphs [0011], [0014], [0017]) that by perpendicular is not meant the direction perpendicular to the surface of the sheet metal strip, but perpendicular to the longitudinal extent and in a plane which runs essentially parallel to the surface of the sheet metal strip. This is confirmed by the figures in the patent application.

C. COUNTERCLAIM FOR REVOCATION

56. The revocation counterclaim of defendant 1 is unfounded. The granted version of the patent in suit is already legally valid. The asserted grounds for invalidity do not apply.

I. Novelty of claim 1

The subject-matter of claims 1 to 11 is novel over the prior art cited against novelty, Art. 65(2) EPC in conjunction with Art. 138(1)(a), Art. 54(1), (2) EPC. Art. 138(1)(a), Art. 54(1), (2) EPC.

1. Legal standard of the novelty test

57. An invention is deemed to be new if it does not form part of the state of the art. The assessment of novelty within the meaning of Art. 54 (1) EPC requires the determination of the overall content of the prior publication. It depends on whether the subject matter of the patent in suit with all its features is directly and unambiguously disclosed in the citation (UPC_CoA_182/2024, order of 25 September 2024, para. 123 - Mammut v. Ortovox).

2. Novelty compared to DE 1 871 426 U (DE'426; Annex LS 6)

58. According to this provision, the subject-matter of patent claim 1 is new compared to DE 1 871 426 U (hereinafter: LS 6). In LS 6, it is at least not clearly and directly disclosed that, in the case of a sheet metal strip with one end face, a connecting end in the form of a tongue (feature 2.3.2) is formed in the region of this end face.

59. LS 6 does not clearly and directly disclose whether the sheet metal parts shown in Figs. 3 and 4 referred to by the first defendant have an end face. Figs. 3 and 4 of LS 6 only specifically depict the area of the connection between the two sheet metal parts 1, 2. The shape of the sheet metal parts outside of this specifically depicted area is left open in LS 6. The respective "free edges" of the sheet metal parts 1, 2 are shown in Figs. 3, 4 of LS 6 with wavy lines. For a person skilled in the art, this is a form of representation regularly used in technical drawings, which indicates that the object shown only in section in the figure extends even further, but that the shape of the other sections of the component not shown are not relevant for understanding the section specifically shown.

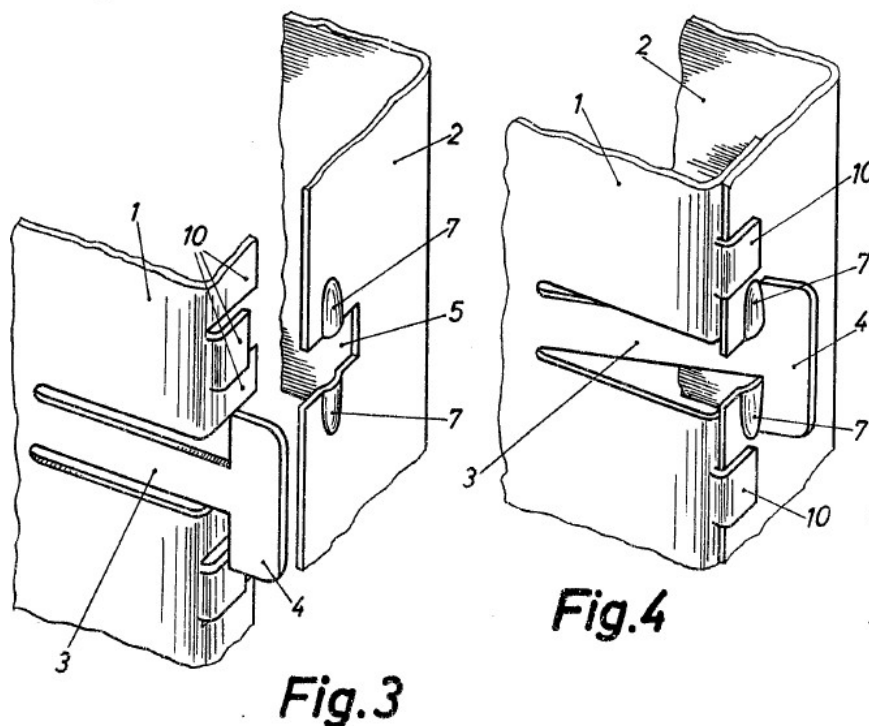

60. The form of representation of the sheet metal parts 1, 2 chosen for Figs. 3, 4 therefore leaves open how far they extend - in the view of Figs. 3, 4 - upwards and downwards and to the left. Thus, it is also not directly and clearly revealed that the bent edge of the component 1 (the transition from the part of the component labelled with the reference sign 1 to the part forming the tabs 10) is a longitudinal side at all. Nothing in Figs. 3, 4 indicates that the component would still extend upwards and/or downwards in such a way that a person skilled in the art would recognise a "long side" therein.

61. If one were to agree with the defendant re 1 (nullity counterclaim, para. 56) that the bent edge of the component 1 is a flange of the sheet metal part 1 along its upper longitudinal side, the crossbar 4, which it sees as a "tongue", would not be a connecting end formed as a tongue in the region of an end face (feature 2.3), but a connecting end formed in the region of the longitudinal side, contrary to the definition of feature 2.3.2.
62. Nothing else results from Fig. 4 of LS 6 submitted in para. 65 of the statement of 20 February 2025 (duplicate in the infringement proceedings and replica in the nullity counterclaim proceedings, hereinafter referred to as replica NWK in this context), supplemented with handwritten explanations, which is copied below.

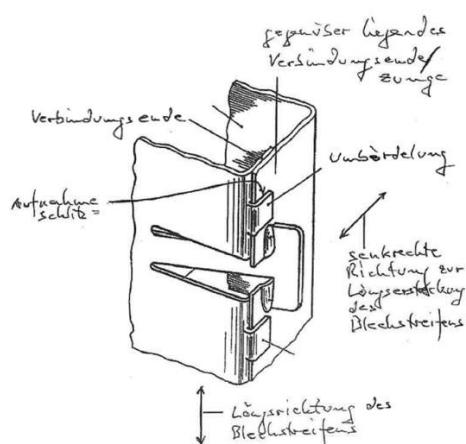

63. Here too, the defendant re 1 does not specify where it believes the end face should be formed. It is true that it claims (para. 77 of the replica mentioned) that the handwritten explanation in Fig. 4 shows that the sheet metal strips (sheet metal parts 1, 2) form connecting ends in the area of the end faces of the sheet metal strips. However, it is not possible to recognise where they locate the ends of the sheet metal strips from the above copied Fig. 4, which was added to by the defendant 1 in handwriting. Even if the above drawing of the defendant 1 were to regard the tab (reference number 10 in Fig. 4) as a receiving slot and the bent area of the opposite sheet metal part as a tongue instead of the crossbar 4, it would not be directly and clearly disclosed for the above reasons that this tongue is formed on the end face.
64. Furthermore, feature 2.3.6 is also not disclosed. The tab with the reference number 10 (Fig. 4), which is intended as a receiving slot, is not perpendicular to the longitudinal direction shown in Fig. 4 by the defendant 1.

1 in the sense of the feature, because it can only be attached perpendicular to the surface of the alleged longitudinal side. The same applies to the recess referred to as the receiving slot, into which the crossbar 4 referred to as the tongue engages.

3. Novelty compared to US 2006/0150480 A1 (US'480; Annex LS 11)

65. The subject matter of patent claim 1 is new compared to the publication US 2006/0150480 A1 (hereinafter: LS 11) already discussed as prior art in the patent application (para. [0007]). In LS 11, it is at least not clearly and directly disclosed that a receiving slot (into which a tongue engages) can be attached to the tongue at the other end of the connection in a direction perpendicular to the longitudinal extension of the metal strip (feature 2.3.6).

66. If the top heam 710a in Fig. 7 of LS 11 referred to by the defendant re 1 were to be regarded as a receiving slot, this heam would not be attachable to a tongue of one sheet metal strip, but to a separate connecting piece ("connecting shim 716"), which cannot be clearly assigned to one of the sheet metal strips to be connected in comparison to the other. In any case, however - contrary to the definition of feature 2.3.6 - the receiving slot would be attachable to the supposed tongue in a direction parallel to the longitudinal extension, as the arrows provided in Fig. 7 copied below emphasise once again.

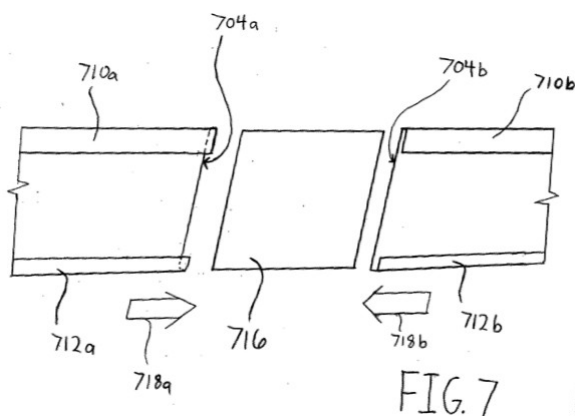

67. Nothing else results from Fig. 4 of LS 11, copied below, where the connection is also made parallel to the longitudinal extension by pushing the element 402, which is regarded as a tongue, into the seams of another sheet metal part at point 404, which are regarded as receiving slots.

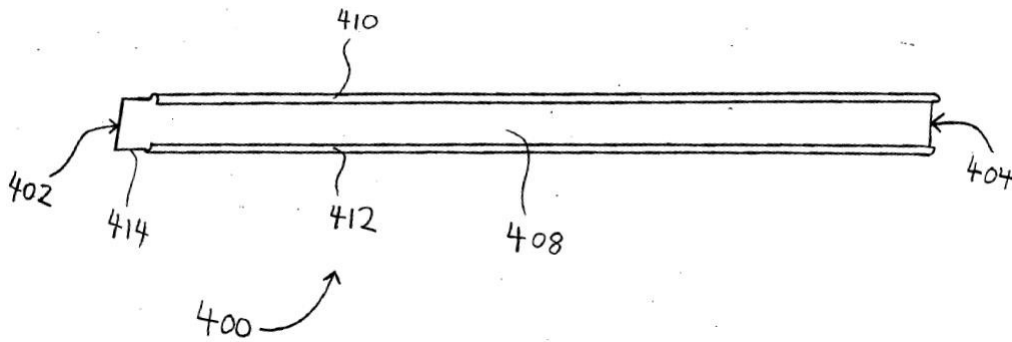

68. Even on the basis of the incorrect submission of the first defendant, there would moreover be a lack of evidence that feature 2.3.6 is disclosed in LS 11, since they themselves state (Reply NWK, para. 91) that Annex LS 11 leaves open how the receiving slot 16 is pushed onto the tongue 4 at the other end of the connection relative to the longitudinal extension of the sheet metal strip.

4. Novelty compared to DE 299 01 263 U1 (DE'263; Annex LS 7)

69. If the first defendant in para. 110 of the reply NWK wanted to assert a lack of novelty of the subject-matter of claim 1 vis-à-vis LS 7 by claiming that the publication DE 299 01 263 U1 (hereinafter: Annex LS 7) "therefore anticipates all features M1.3 to M1.9", this objection would have to be rejected as belated. It is neither stated nor otherwise apparent why it raises such an objection only in the reply NWK. LS 7 was already submitted with the nullity counterclaim, but there it was only objected to an inventive step.

70. Moreover, the arguments of defendant 1 are not convincing, at least with regard to feature 2.3.6. The copy of Fig. 7 of LS 7 submitted by it in para. 94 of its Reply NWK, labelled with a handwritten annotation, misrepresents the disclosure content of Fig. 7 (and the associated description). The Fig. 7 (left), Fig. 7 (centre) of LS 7 and Fig. 2 (right) of LS 7 labelled by the defendant re 1 are copied below.

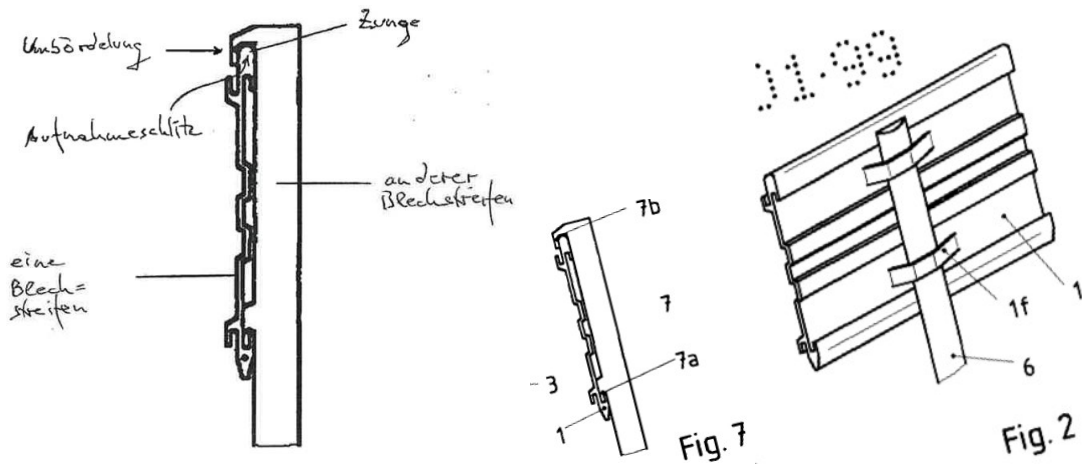

71. According to the explanation in the third paragraph of page 4 of LS 7, the object provided with the handwritten comment "other sheet metal strip" is an earth nail 7, i.e. an object which is used in a similar way to the earth nail 6 shown in Fig. 2 of LS 7. This alone casts doubt on whether the object "other sheet metal strip" is a sheet metal strip within the meaning of claim 1.
72. Even if the peg 7 were to be regarded as a sheet metal strip, the "one sheet metal strip" and the "other sheet metal strip" in the annotated copy of Fig. 7 above would not be connected to each other at the end face, as feature 2.1 requires of the two sheet metal strips of the border of claim 1. This is because the part of the "one sheet metal strip" labelled by the defendant 1 as "tongue" is actually its upper longitudinal side. The upper longitudinal side is inserted into the groove of the peg 7, which the defendant refers to by hand as a "flange", so that the upper end of the peg 7 is connected to the longitudinal side of the "one metal strip".
73. In the alternative embodiments further referred to by the defendant re 1 (replica NWK, para. 98), connecting elements 2, 3 are provided which, according to the text passage referred to by the defendant on page 4, 2nd paragraph, are inserted into grooves 1a and 1b of belt 1. In these embodiments, the connecting ends of the two straps 1 to be connected are therefore - contrary to feature 2.3.1 - not arranged to overlap one another. Rather, the connecting end of one strap 1 is arranged overlapping with the connecting element 2, 3, but at a distance from the connecting end of the other strap 1, which in turn is arranged overlapping with the connecting element 2, 3, without the connecting elements being able to be assigned to one or the other strap, and certainly not as a component.

II. Inventive step of claim 1

74. The subject-matter of claims 1 to 11 is based on inventive step over the prior art cited in the proceedings, Art. 65(2) EPC in conjunction with Art. 138(1)(a), Art. 56 EPC. Art. 138(1)(a), Art. 56 EPC.

1. Legal standard for the examination of inventive step

75. According to Art. 56 EPC, an invention is deemed to involve an inventive step if it is not obvious to a person skilled in the art from the state of the art.

76. Even if it is not absolutely necessary to choose a single starting point and it is conceivable in the context of the examination of inventive step to examine the inventive step from different starting points, at least one starting point is required for this examination in order to understand whether the invention was obvious to the skilled person from the prior art. It also requires a justification as to why the skilled person would consider the selected part of the prior art as a realistic starting point. This is the case if its teaching would have been of interest to the person skilled in the art at the relevant priority date when faced with the task of developing a similar product or process to that disclosed in the prior art which has a similar underlying technical problem to the claimed invention. In general, a second step then requires an inducement or suggestion to follow the path of the invention based on the starting point (see in particular Munich Central Division, decision of 16 July 2024, UPC_CFI_1/2023, p. 24 ff.). The use of a particular means may exceptionally be suggested even without a separate inducement or suggestion if, by its nature, it is a general means to be considered for a large number of applications and belongs to the general knowledge of the skilled person concerned, the use of the functionality in question is objectively expedient in the context to be assessed and no special circumstances can be identified which make its use appear impossible, difficult or otherwise impracticable from a technical point of view (cf. LD Mannheim, decision of 2 April 2025,

UPC_CFI_359/2023, para. 121 with reference to BGH, Urt. v. 15 June 2021 - X ZR 58/19, GRUR 2021, 1277 para. 47 - Guide rail arrangement).

77. The statements of the defendant re 1 in the action for annulment do not indicate which starting point it chooses for its considerations. Apart from that, it does not show why the skilled person had cause to arrive at the subject-matter of the invention protected in claim 1 in his considerations.

2) *Inventive step based on LS 7*

78. Assuming in its favour that the defendant re 1 sees LS 7 as the starting point in its nullity action (which it cites as the only document on the generic term "edging for beds and grassland areas"), its submission in the nullity counterclaim lacks any explanation as to why it should have been obvious to the skilled person, based on LS 7, to further develop the ribbon-shaped edging for plants described in LS 7 in such a way that

- it has the feature 2.2 (feature 1.3 in the parties' classification) not identified by the first defendant in the cancellation counterclaim in SP 7 itself, according to which the bleaching strips have longitudinal sides and are flanged at least on these sides;
- it has feature 2.3.2 (feature 1.6 in the parties' classification), which is not itself identified by defendant 1 in the counterclaim for cancellation in SP 7, according to which one end of the connection is designed as a tongue;
- has features 2.3.3 and 2.3.4 (feature 1.7 in the parties' specification), which were not identified by the first defendant itself in the cancellation counterclaim in LS 7, according to which a receiving slot is arranged at the opposite end of the connection and the tongue engages in the receiving slot.

79. However, such a submission would have been necessary in order to cast doubt on the inventive step underlying the subject-matter of claim 1, because the first defendant did not refer to LS 7 for any of the above-mentioned features in the statement of defence.

80. Contrary to the approach chosen in the revocation counterclaim (para. 84 et seq.), it is also not sufficient, according to the above-mentioned requirements for demonstrating obviousness, to describe the

In addition, it is not sufficient to prove the features of the claim individually in separate prior art documents without showing why the person skilled in the art had cause to make a combination of the printed documents corresponding to the subject-matter of the patent in suit or, exceptionally, why a specific cause is not required.

81. It is irrelevant whether the supplementary submission in the reply NWK (para. 94 to 191) is to be regarded as belated, as it does not justify a different result. There, the first defendant makes it clear for the first time that its considerations on inventive step are based on LS 7.
82. Contrary to the statements of the first defendant in its reply NWK (para. 94 to 110), LS 7 is not in itself capable of suggesting the subject-matter of claim 1.
83. As explained above with regard to novelty, feature 2.1 (connectable to each other at the end face) or 2.3.1 (connecting ends inserted into each other in an overlapping manner) is initially lacking, depending on the embodiment example. The defendant's submission does not indicate how the skilled person was to arrive at the design features missing in LS 7 in an obvious manner.
84. Nothing else applies to the submission in the replica NWK on further prior art in connection with LS 7 (Annexes LS 4 to LS 6, LS 8 to LS 11).
85. There (para. 122 to 130), Defendant 1 first explains feature 2.1 (feature 1.2 in the parties' classification). However, it does not show how, in the embodiment according to Fig. 7 of LS 7, in which this feature is missing, one of the further printed documents cited could instruct the skilled person to redesign the connection shown there between the upper longitudinal side of the sheet metal strip and the end of the earth nail 7 (assumed to be a sheet metal strip) in this embodiment example of LS 7 in such a way that two sheet metal strips would be connected to each other at the ends.
86. In para. 149 to 157 of the Reply NWK, the defendant re 1 explains feature 2.3.1 (feature 1.5 of the parties' classification). However, it does not show how, in the embodiment of the LS 7 with connecting elements 2,3, in which this feature is missing, one of the cited other printed publications could instruct the skilled person to use in this embodiment example

of the LS 7 to abandon the spacing of the connecting ends of the metal strips 1 shown there and to make their connecting ends mutually overlapping and inserted into one another.

87. Irrespective of the above, feature 2.3.6 is also missing in the embodiments of LS 7 with and without connecting elements 2, 3, according to which the receiving slot can be pushed onto the tongue at the other connecting end in a direction perpendicular to the longitudinal extension of the metal strip. The strips are pushed into each other parallel (and not perpendicular) to their longitudinal extension using a tongue and groove system (see Figs. 1, 3, 4, 8, 9, 11, 12). Similarly, the separate connecting elements 2, 3 are pushed into the upper and lower seams of the belts parallel to their longitudinal extension (Figs. 5, 6, 10). In turn, the submission of the defendant 1 does not indicate how the skilled person, starting from LS 7, in particular the Fig. 3 referred to, should arrive in an obvious way at a design having feature 2.3.6. It is true that in one embodiment (Fig. 7 and probably also Fig. 13 for pegs 7 and 10, different Fig. 14 for peg 11) the peg 10 is pushed from above onto the strip 1 or 9, so that the upper hook 7b, 10a of the peg 7, 10, possibly to be regarded as a receiving slot, can be pushed from above onto the spring element 1c, 9c of the strap 1, 9 or the groove element 9b of the strap 9, possibly to be regarded as a tongue, but not located on the end face. However, it has not been shown (nor is it otherwise apparent) why the skilled person should take the design of the earth nails as an opportunity to modify the tongue and groove system of the straps in such a way that the straps are no longer pushed into one another parallel to their longitudinal extension, but instead one strap is pushed onto the other from above.

88. The submission of the defendant re 1 (Reply NWK, para. 185 to 189) on further prior art in connection with feature 2.3.6 (in its structure feature 1.9) also does not indicate why it should be obvious for a person skilled in the art to modify the specific embodiments of the LS 7 with and without connecting elements 2,3, in particular the Fig. 3 referred to, in such a way that a receiving slot could be attached to the tongue at the other connecting end in a direction perpendicular to the longitudinal extension of the metal strip.

III. Legal validity of subclaims 2 to 11

89. The novelty of the subject-matter of sub-claims 2 to 11 is already apparent from their reference back to and further development of the new subject-matter of claim 1. The same applies with regard to the inventive step.

D. PATENT INFRINGEMENT

90. At least two composite lawn and design edges of the contested embodiment realise the teaching of claim 1 of the patent in suit (see I.). The realisation of the other features from the "in particular" additions of the applications is irrelevant (see II.). By the acts complained of, the first defendant directly infringes the patent in suit in Austria as well as in Germany and Luxembourg. However, the defendants 2 and 3 are not jointly responsible for the patent infringement (see III.). This results in the pronounced legal consequences (see IV.).

I. Realisation of the features of claim 1 of the patent in suit

91. At least two lawn and design edges of the contested embodiment, which are assembled as intended, realise the features of claim 1 of the patent in suit. This is not in dispute between the parties due to patent law considerations with regard to features 2., 2.1., 2.2, 2.3, 2.3.3, 2.3.5 and 2.3.6, but also applies to the disputed features 2.3.1.

but also applies to the disputed characteristics 2.3.1, 2.3.2, 2.3.4 and 2.3.6.

1) Feature 2.3.2 - tongue

92. In the contested embodiment, one end of the connection is designed as a tongue (feature 2.3.2, feature 1.6 in the parties' subdivision). This tongue has been emphasised by the plaintiff with a red box in the illustration on page 9 of the application (left-hand illustration), which is reproduced below.

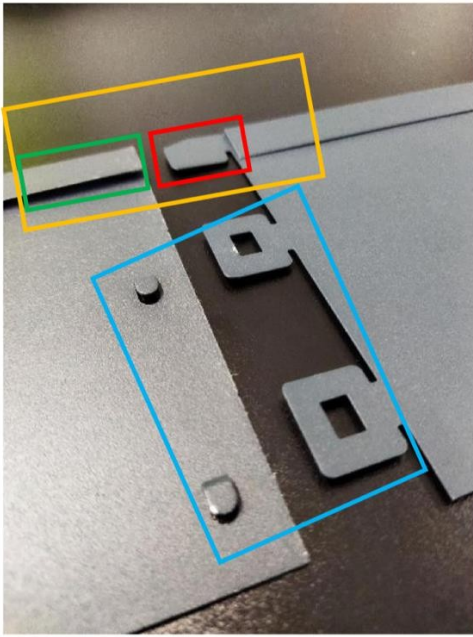

93. The design is not in fact in dispute between the parties. Insofar as the defendants come to a different conclusion (see in particular the statement of defence, paras. 26 to 28), this is based on an incorrect understanding of feature 2.3.2. As discussed above, the claim allows the connecting end designed as a tongue to be narrower than the width (height) of the metal strip (see Fig. 9 of the patent specification). In particular, it therefore does not result from the realisation of this feature that the connecting element to be regarded as a tongue in the attacked embodiment, as the defendants state (statement of defence, para. 27), is clearly set off from the metal strip as such.

2) Feature 2.3.1 - Connecting ends inserted into each other in an overlapping manner

94. In the assembled state, the connecting ends of the contested lawn and design edges overlap each other (feature 2.3.1, in the parties' classification feature 1.5).

95. With the two images copied below from page 9 of the statement of claim, which show the not yet assembled end faces of the metal strips on the left and the properly assembled end faces on the right, the plaintiff has shown that the tongue (outlined in red in the left image) engages in the receiving slot (outlined in green in the left image) when the attacked lawn and design edges are assembled and thus comes into a position that can be deduced by the skilled person from the right image, in which the tongue engages with the opposite connecting end, at which the

opposite end of the connection, where the receiving slot is located, overlaps on the opposite side.

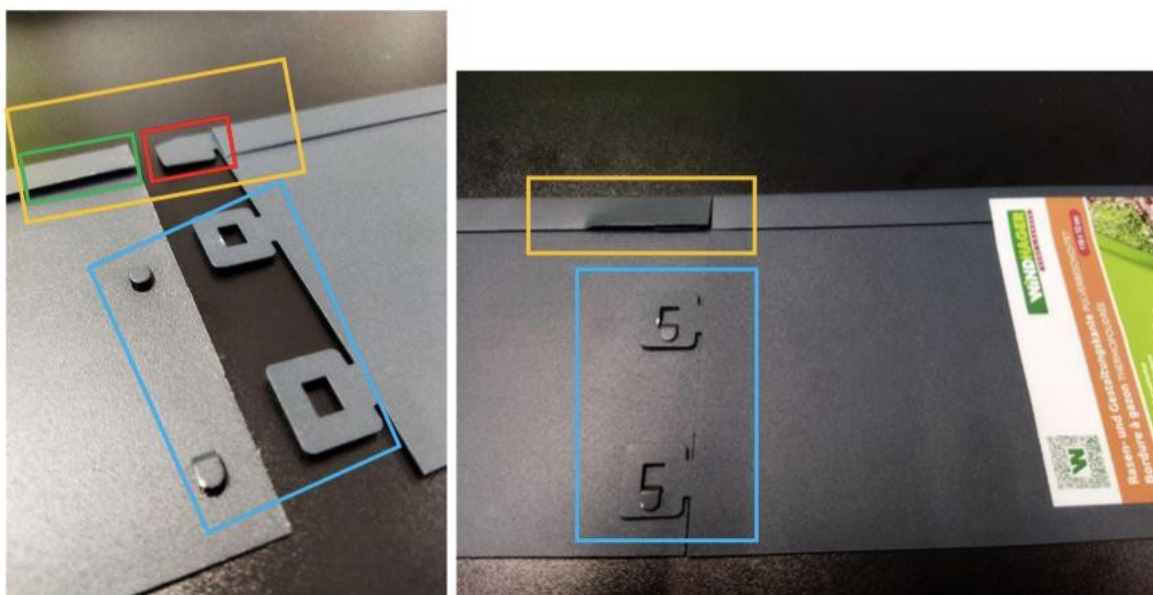

96. Again, the defendants have not disputed this finding of fact. Insofar as they come to a different conclusion (cf. in particular statement of defence, paras. 23 to 25), this is based on an incorrect understanding of feature 2.3.1. They are of the opinion that the connecting end must extend over the entire width (height) of the end face of the metal strip and regard only its edge with the area next to it facing away from the tongue as the connecting end of the turf and shaping edge on the side of the tongue. Therefore, as discussed at the hearing, they come to the conclusion that the connecting ends of the contested turf and design edges do not overlap in the assembled state, but lie butt to butt with their edges.

97. As explained, however, claim 1 does not require that the connecting end in the form of a tongue extends over the entire width (height) of the end face of the metal strip. The same applies to the connecting end co-operating with the tongue on the other end face. The connecting end of the attacked embodiment formed by the tongue is thus limited to the tongue outlined in red in the above figure, which in the assembled state is inserted into one another in a mutually overlapping manner with the opposite connecting end.

98. Even if the entire width (height) of the end face were to be regarded as the connecting end, the tongue outlined in red in the above illustration would not overlap with this connecting end.

still overlap, since, as discussed, a certain degree of overlap is not required. Apart from this, as also discussed, claim 1 does not exclude a further connecting end on one end face next to the connecting end formed as a tongue, nor does it exclude a multi-link tongue. Therefore, if the two projections of the interlock located in the blue border of the above figure are also regarded as connecting ends of one end face, the degree of overlap would be even greater if the entire width (height) of the other end face in the connecting area were to be regarded as the connecting end there.

3) *Feature 2.3.4 - Tongue engages in the receiving slot*

99. In the assembled state, the element of a tapped turf and design edge to be regarded as a tongue engages in the part of the flange slightly raised from the metal strip and thus in the receiving slot of another turf and design edge (feature 2.3.4, in the parties' classification part of feature 1.7). Again, the defendant's deviating understanding is not based on a deviation in fact, but on a different understanding of the tongue.

II. *Realisation of the characteristics of the "in particular" additions*

100. It is not necessary to determine whether the characteristics of the "in particular" additions have been realised. The characteristics do not further limit the scope of a conviction under claim 1. Apart from that, the plaintiff has recognisably only asserted them for the (non-occurring) case that the patent in suit is partially revoked in the granted version and maintained in the corresponding version defended in the alternative.

III. *Patent infringing acts*

1) *Applicable substantive law*

101. The substantive law of the UPCA applies to the contested acts committed after the entry into force of the UPCA on 1 June 2023, as well as in principle to acts commenced before and continued after that date, whereas the national substantive law of the UPCA contracting member state in question applies to acts committed before and already completed on 1 June 2023. For further details, please refer to the

decisions of the Local Division Mannheim of 11 March 2025 (UPC_CFI_159/2024, UPC_CFI_162/2024, Hurom ./ . NUC Electronics and others).

2) Acts of the defendant 1

Austria

102. Defendant 1 offered the attacked embodiment on its Austrian websites www.windhager.eu/at in Austria after 1 June 2023. There is no dispute between the parties that the screenshots submitted by the plaintiff authentically reproduce the websites and originate from the year 2024.
103. The contested embodiments are advertised for sale via these websites and are thus offered in accordance with Art. 25(a) UPCA. Whether an act is an offer in this sense depends on the explanatory value to be attributed to it, which is to be determined from the objective point of view of the relevant public, taking into account all the circumstances of the individual case.
104. In the case in dispute, the fact that the contested embodiments labelled as lawn and design edges are shown individually in close-up does not preclude an offer. It does not follow from this that the offer would be limited to the sale of individual lawn and design edgings. Rather, it follows from the context that several lawn and design edges are offered for assembly by the customer. By way of example, reference is made to the screenshots included below:

Resen- und Gestaltungskante | X +

https://www.windhager.eu/Products/Rasen-und-Gestaltungskante_a_E7831

PRODUKTE

RASEN- UND GESTALTUNGSKANTE

- variable Rasenkante zur Abtrennung von Rasen und Gehwegen
- individuelle Gestaltungsmöglichkeiten
- einfach zu montieren, beliebig verlängerbar
- langlebig und stabil
- moderne Optik in anthrazit oder verzinktem Metall



VARIANTEN

Art.-Nr.	Bezeichnung	Variante ansehen
0280	Rasen- u. Gestaltungskante anth. 118x12cm	ANSIHEHEN
0287	Rasen- u. Gestaltungskante anth. 118x12cm	ANSIHEHEN
0288	Rasen- u. Gestaltungskante anth. 118x12cm	ANSIHEHEN
0289	Rasen- u. Gestaltungskante anth. 118x12cm	ANSIHEHEN

Produktbeschreibung

Obenlig, gerade oder rund kein Problem für die flexible Rasenkante.

Zielsetzt Selbstk. Die langlebige und stabile Rasenkante sorgt für eine effektive, schnelle Zäunung für Ihren Rasen von Bereichen mit Kies, Sand, Schotter, Bröckelstein, Blähton, Geröll für die Zäunung des Rasens vor Gehwegen in unterschiedlicher Komplexität aus Beton und Formstein Material. Ihre Gestaltungsmöglichkeit können mit der beliebigen Fassadenfarbe beliebig verlängert werden, erfüllt werden. In zwei modernen Ausführungen: anthrazit oder anthrazit - vergrünbar.

Starkes und sauber

Mit präzise Anbringen durch Vorbohren, an einer die Rasenkante fest im Boden und überlagert mit einer Flexibilität, die selbst Kurven und Ecken spielend meistert. Eine einfache annehmbare Rasenfassung für einen gepflegten Garten.

PRODUKTE: Caran, Instandschutz, Schlagschutz, Sonnenschutz

UNTERNEHMEN: Wir sind Windhager, Karriere, Presse, Jobs

SUPPORT: Kontakt, Video, Downloads

KONTAKTIEREN SIE UNS: Instandschutz, Kooperations-Hilfe, +49 3688 030 133, +49 3688 030 413, Caran-, Schlagschutz- und Sonnenschutz, +49 3688 030 413

FOLGEN SIE UNS: [Social Media Icons]

© 2021 Windhager Home & Garden

(Annex K3.2)

Resen- und Gestaltungskante | X +

https://www.windhager.eu/Products/Rasen-und-Gestaltungskante_a_E7831

WINDHAGER

PRODUKTE UNTERNEHMEN KARRIERE SUPPORT

Startseite > Rasenkanten > Rasen- und Gestaltungskante

PRODUKTE

RASEN- UND GESTALTUNGSKANTE

- variable Rasenkante zur Abtrennung von Rasen und Gehwegen
- individuelle Gestaltungsmöglichkeiten
- einfach zu montieren, beliebig verlängerbar
- langlebig und stabil
- moderne Optik in anthrazit oder verzinktem Metall



VARIANTEN

Art.-Nr.	Bezeichnung	Variante ansehen
05838	Rasen- u. Gestaltungskante verz. 118x12cm	ANSIHEHEN
07457	Rasen- u. Gestaltungskante anth. 118x12cm	ANSIHEHEN
07618	Rasen- u. Gestaltungskante verz. 118x12cm	ANSIHEHEN
07619	Rasen- u. Gestaltungskante anth. 118x12cm	ANSIHEHEN

Cookie Einstellungen

(Annex K3.1)

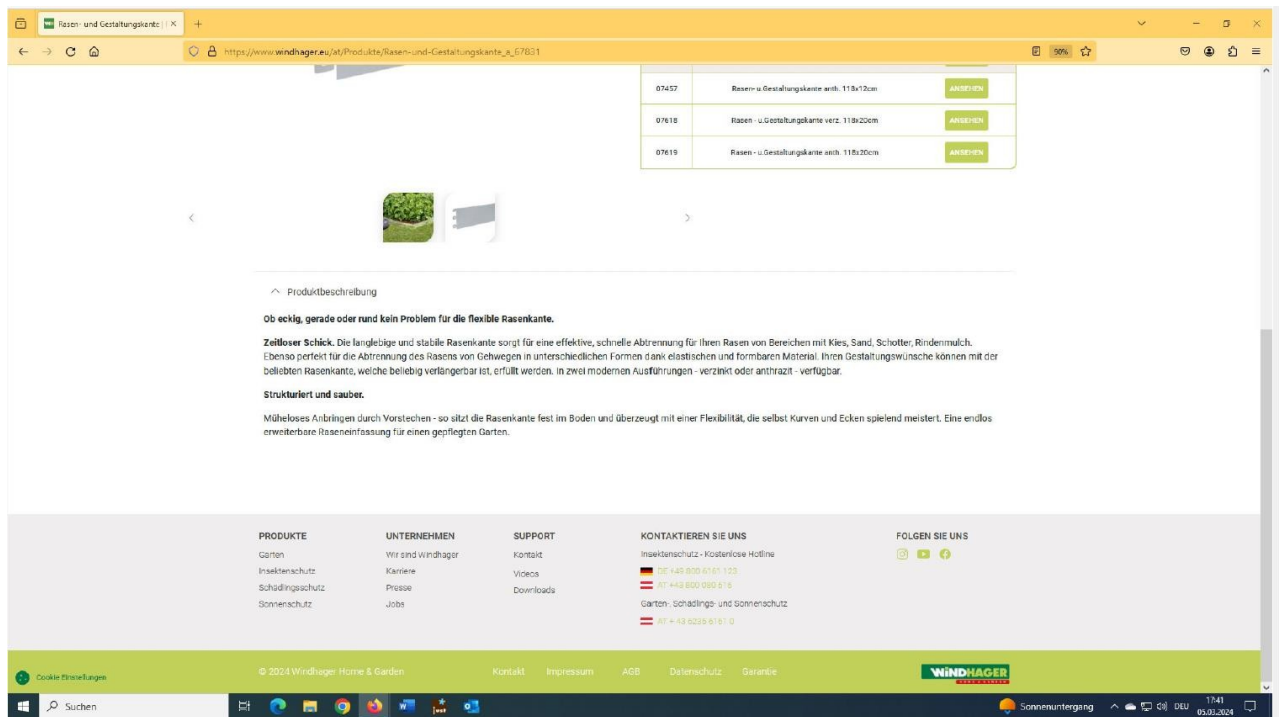

(Annex K3.3)

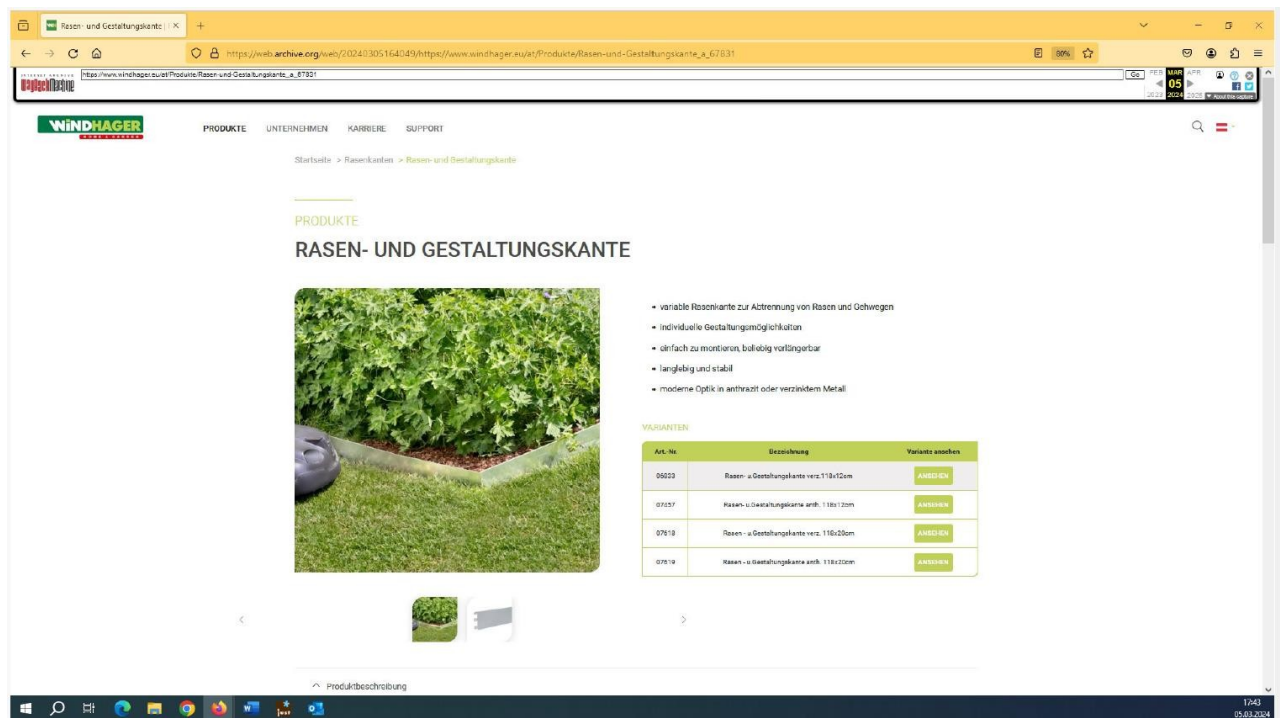

(Annex K3.4)

105. These show not only two lawn and landscaping edges combined to form a corner border (preview image in Appendix K3.2, enlarged view in Appendix K3.4).

Rather, it is emphasised that the variable lawn and design edging is easy to install and can be extended as required and offers individual design options (e.g. Annex K3.1, K3.4) and that the lawn edging, which can be extended as required ("whether square, straight or round, no problem for the flexible lawn edging"), enables endlessly extendable lawn edging (e.g. Annex K3.3, K3.5). These circumstances are sufficient to attribute to the offer the explanatory content that the lawn and design edging are not merely offered individually. It is therefore not necessary at this point to consider in detail whether an offer which is limited to the sale of a lawn and design edging as a single piece is an offer within the meaning of Art. 25(a) UPCA (cf. IV.1 below).

106. The fact that the screenshots submitted as Annexes K3.1 to K3.10 may not show all patent-infringing features, as the defendants believe, is irrelevant. The defendants do not dispute that these offers relate to the same contested embodiment which was the subject of the plaintiff's test purchase in Germany and for which the plaintiff submitted the photographs discussed above.
107. Against this background, the plaintiff was entitled to assert, without this being regarded as an irrelevant declaration in the blue, that the defendant 1 also supplied several lawn and design edges of the attacked embodiment to a customer in Austria after 1 June 2023 and thus placed them on the market there (Art. 25(a) UPCA). The defendants have not significantly denied this in fact. In particular, they have not alleged that Defendant 1 only sold the lawn and design edging individually in Austria after 1 June 2023 and refused orders for more than one lawn and design edging.
108. It is irrelevant for the direct patent infringement that the lawn and design edgings are obviously only offered in a non-assembled state and delivered to customers in Austria. It is true that claim 1 only covers edgings composed of at least two lawn and design edges. However, as shown not least by features 2.1 and 2.3.6, the embodiment according to the invention is designed precisely for the sheet metal strips to be assembled in a simple manner at the place of use without the addition of further objects (see also paragraphs [0011] to [0014]). In any case, in such a case, the offering and sale of all components of an infringing product, which are assembled in a modular system at the place of use, already constitutes an infringement of the patent.

in a modular system at the place of use by the customer without the addition of further articles only has to be assembled in a simple manner in accordance with the intended purpose, constitutes direct patent infringement within the meaning of Art. 25 EPC.

Germany

109. Offering and placing on the market in Germany after 1 June 2023 can also be assumed. The plaintiff has asserted such in a considerable manner, since the attacked embodiment is available on the market in Germany, as evidenced by the test purchase from 2024 (Annex K4, K5), and the defendant 1 maintains a contact form on its website for contact enquiries from business partners as new customers, which provides for Germany, among other countries, in the country selection (cf. replica in the defence proceedings, p. 12 f.). The defendants have not substantially disputed the allegation. In particular, the complaint that there is no evidence of infringing acts and that the test purchase is not attributable to defendant 1 is not sufficient. Rather, the defendants would have had to assert decidedly that the attacked embodiment is not made available for distribution by business partners in Germany, in particular that the source of the test purchase in Germany is not (indirectly) supplied by the defendant 1, and that orders from end customers from Germany are not accepted and how this is ensured according to the internal organisation of the defendant 1.

Luxembourg

110. Finally, a patent infringement in Luxembourg after 1 June 2023 must also be assumed. It is true that the plaintiff does not indicate a selection option for Luxembourg in the contact form for business partners. However, the plaintiff had good reasons to claim a delivery and an offer also for Luxembourg, after the defendant 1 had requested a licence also for Luxembourg in the pre-trial licence negotiations. Against this background, the defendants should have stated clearly that orders from Luxembourg are not processed and how this is ensured by their internal work organisation. Furthermore, they should have explained that the request for a licence for Luxembourg was not based on deliveries already made or preparations for imminent deliveries to Luxembourg and, if so, why.

3) Acts of the defendants 2 and 3

111. In contrast, it has not been established that the defendants 2 and 3 are responsible for the patent infringing acts of the defendant 1 as their managing director.

Applicable law

112. Whether a management body of a company is exposed to its own patent law claims due to a patent infringement of the company depends in principle on the substantive law applicable to the patent infringement in question in accordance with the relevant country of protection principle, which also determines the scope of protection of patent law against acts to be assessed. Whether liability may also arise in individual cases from the applicable company law and whether the EPC's power of cognizance under Art. 32 UPCA extends to claims mediated by company law, for which a patent infringement is merely a preliminary question, does not need to be decided in the case in dispute because it is not apparent that the plaintiff is relying on such liability of the defendants 2 and 3, which establishes a different subject matter of the dispute than a patent infringement by the defendants 2 and 3.

Acts of infringement after 1 June 2023

113. Under the UPCA, it is not sufficient for the managing directors of a company to be managing directors in order to assume that they have infringed a patent themselves. In this respect, the same applies as for liability under Art. 63 (1) sentence 1 UPCA as an intermediary, for which the mere function as managing director is also not sufficient (see Court of Appeal, order of 29 October 2024, GRUR-RS 2024, 29496 para. 66). Rather, the managing director must at least be involved in the specific patent infringement in question.

114. The plaintiff's submission is limited to the assertion that the acts considered to be patent infringing "take place under the control of the managing directors of defendant 1, which means that defendants 2 and 3 must also be sued before the local court seized." Since, due to the statutory power of control, all actions of a company are carried out under the control of the managing directors, this submission does not go beyond the mere assertion of liability by virtue of the position of managing director, which is not sufficient according to the above.

115. It is irrelevant whether a participation of the managing directors is assumed under certain circumstances, as such circumstances have neither been presented nor are otherwise apparent. According to the defendant's submission, which is not significantly disputed, the product portfolio includes a variety of goods in the garden, insect protection, pest protection and sun protection sectors (statement of defence, para. 10). In the extract from the defendant's website submitted as Exhibit 1, the product range comprises more than 7,000 articles. Against this background, it is in particular not apparent that the challenged embodiment is of such importance in the business operations of Defendant 1 that its design and its inclusion in this specific design in the product range is not usually decided without involving the management level. Similarly, in the absence of any evidence, it can be left open whether managing directors are liable for patent infringement even without specific involvement in the distribution of a patent-infringing product if they are at fault in the organisation of the business operations, which leads to the patent law situation not being properly examined and observed by the company.

116. Again, no submission has been made that the pre-trial settlement negotiations and the pre-trial and judicial claims against defendants 2 and 3 in addition to defendant 1 would justify a different assessment.

Acts of infringement before 1 June 2023

117. Insofar as German, Austrian or Luxembourg law may be applicable to acts committed before 1 June 2023, this does not lead to a different result.

118. Insofar as national German, Luxembourg and Austrian law is applicable to acts committed before 1 June 2023, the plaintiff, who is burdened with the burden of proof, has also not shown why the defendants 2 and 3 are liable. However, such an explanation would have been necessary and reasonable because it cannot be assumed that a local division knows the law of all UPC contracting member states (see Mannheim Local Division, decisions of 11 March 2025, UPC_CFI_159/2024, UPC_CFI_162, para. 101 and 105 - Hurom ./ NUC Electronics and others).

IV. Legal consequences

119. In accordance with the above, the action against defendants 2 and 3 must be dismissed. The legal consequences ordered result from the established patent infringement of defendant 1.

1) Injunction

120. The claim for injunctive relief against Defendant 1 follows from Art. 25(a) in conjunction with Art. 63(1) sentence 1 EPC. Art. 63(1) sentence 1 UPCA.

121. The injunction also extends to the act of use of manufacturing, since the first defendant claims to be active as a manufacturer (statement of defence, p. 3), without denying the manufacture of the attacked embodiments in the territory of the UPCA states relevant here. In any case, there is a serious risk of manufacture in these countries. The same applies to use, at least for demonstration purposes, especially since the website also shows assembled lawn and design edges (cf. for example Annex K3.4), and to possession for the aforementioned purposes. Insofar as the lawn and design edgings are not manufactured in Germany, Austria or Luxembourg, they have been imported there for the aforementioned purposes or there is a serious risk of this. Against this background, it is irrelevant whether the realisation of the act of offering and placing on the market already justifies an extension to the other acts of use. Since acts of infringement are established in all three asserted UPCA contracting member states (cf. para. 101 to 109 above), it is further irrelevant whether, in the context of main proceedings, the infringement established in one UPCA contracting member state automatically entails an injunction in the territory of all asserted UPCA contracting member states in which the patent in suit is in force (cf. on territorial extension in the case of an application for interim measures, Court of Appeal, order of 13 August 2025, UPC_CoA_446/2025, 520/2025, para. 91 - Boehringer ./ Zentiva; order of 3 March 2025, UPC_CoA_523/2024, para. 103 f. - Sumi Agro et al ./ Syngenta). Accordingly, it can be left open whether Art. 34 UPCA generally requires such an extension or is merely to be understood as a provision in connection with Art. 71d sentence 2 Brussels Ia Regulation.

122. The injunction also covers the offering and marketing of a single lawn and design edge. If an infringing product consists of at least two identical, coordinated components which, according to their patent-compliant design, are designed to be assembled into the patent-protected product in accordance with the patent without the addition of further objects, the individual sale of such a component already regularly constitutes a direct patent infringement within the meaning of Art. 25(a) UPCA if the possibility of assembly is pointed out.

within the meaning of Art. 25(a) UPCA if the possibility of assembling is pointed out or is otherwise obvious. In the absence of any indications to the contrary, it must then be assumed that the individual component serves to extend the infringing product by a further component in accordance with the patent. This is the case here. The lawn and design edges are each components which, according to the websites of defendant 1, are also sold individually to extend existing edgings (cf. "can be extended as desired", in particular Annex K3.1, K3.3, K.3.4).

123. As can be seen from claim no. 1.2 and its explanation in the statement of 7 July 2025, the plaintiff also objects to the retail sale of the disputed lawn and design edges. The fact that it regards such a sale as indirect patent infringement is harmless.

124. Since, according to the above, the retail sale of a lawn and design edge is also a direct patent infringement under the established circumstances, it is covered by the operative part without the need for separate information on this in the operative part.

2) Recall, removal, destruction

125. The claim for recall, removal from the distribution channels and destruction follows for the first defendant from Art. 63(2)(b)(d) and (c) UPCA.

126. It has not been demonstrated that the aforementioned measures would be disproportionate, nor is it otherwise apparent. Defendant 1, which has the burden of presentation and proof in this respect, neither asserts disproportionality nor does it demonstrate any circumstances in this regard. In particular, it does not assert a possibility of removal other than destruction.

127. A claim for recall and removal from the distribution channels must also be assumed for the specimens of the challenged designs that were placed on the market before 1 June 2023, insofar as national German, Luxembourg or Austrian law is applicable to them. The plaintiff has not submitted any legal basis for this. However, a claim for recourse and removal follows from Art. 10 (1) of the Enforcement Directive to be implemented in all EU Member States, since the defendants do not claim that Austria or Luxembourg or Germany, insofar as this would be permissible at all under the Directive, would have implemented only one of the two measures in the implementation.

3) Information

128. The claim for information against the defendant re 1 follows from Art. 67 (1) UPCA. It also covers periods prior to the entry into force of the UPCA on 1 June 2023 (see Mannheim Local Court, decisions of 11 March 2025, UPC_CFI_159/2024, UPC_CFI_162, para. 103 and 107 - Hurom ./ NUC Electronics and others). There is no express deadline for the provision of information because the plaintiff did not request such a deadline. Even without an express deadline, the defendant 1 is obliged to provide the information immediately after the judgement has become final or the plaintiff has requested it to do so beforehand.

4) Determination of the obligation to pay damages

129. The determination of the first defendant's obligation to pay damages is based on Art. 68(1) UPCA. In any event, the first defendant acted negligently. If it had exercised due care, it should have recognised, in the absence of any indications to the contrary, that the attacked embodiment makes use of the teaching of the patent in suit. A temporal restriction or breakdown of the finding with regard to actions that are subject to national German, Luxembourg or Austrian law is not necessary. Rather, special features of the national law of the UPCA contracting member states that may apply to the past prior to 1 June 2023 only concern aspects of the amount of the calculation of damages, which can only be conclusively assessed on the basis of the information still to be provided and are therefore subject to the separate procedure for determining the amount of damages pursuant to R. 125 et seq.

R. 125 et seq. VerFO (see Local Chamber Mannheim, decisions of

11. March 2025, UPC_CFI_159/2024, UPC_CFI_162, para. 104 and 108 - Hurom ./ NUC Electronics and others).

5) Publication of judgement

130. There is no right to publication of judgement pursuant to Art. 64 (1), Art. 80 UPCA. Due to the general principle of proportionality (see Art. 42 UPCA), publication of the judgement must not be disproportionate. Since the decisions of the UPC are in principle publicly accessible anyway and are published on its homepage, a special justification is required as to why, in addition, a separate publication as a measure under Art. 64 (1) or Art. 80 UPCA is required for redress (see Local Chamber Mannheim, decisions of 11 March 2025, UPC_CFI_159/2024, UPC_CFI_162, para. 130 and 134 mwN - Hurom ./ NUC Electronics and others). The plaintiff has not demonstrated such special circumstances in the case in dispute.

6) Threat of a penalty payment

131. The threat of a penalty payment has its basis in Art. 63(2) UPCA for the injunction and in Art. 82(1), (4) UPCA, R. 354.3 RP for the information and the measures of recall, removal from the distribution channels and destruction. The requested threat of an upper limit does not raise any objections. In the event of an infringement, the penalty payment will be set at a specific, appropriate amount, taking into account the circumstances of the individual case and proportionality.

E. Provision of security

132. Art. 82(2) UPCA, R. 118.8 RoP grants the court discretion to make any order subject to the provision of security. The plaintiff's interest in the effective enforcement of its IP right must be weighed against the defendant's interest in the effective enforcement of possible claims for damages in the event of a subsequent cancellation of the order, taking into account the circumstances of the individual case.

133. The enforcement of possible claims for damages against a plaintiff may be jeopardised by his financial situation, his unwillingness to compensate the defendant or by difficulties in the places where possible claims for damages must be enforced, which make enforcement impossible or unreasonably difficult. Whether and to what extent such factors are present is to be determined on the basis of the

The facts and arguments put forward by the parties must be examined according to the same standards as in the case of an application for security pursuant to Rule 158 RoP. Since the order for security for enforcement serves to protect the defendant, it is first up to the defendant to explain and justify (and, if necessary, prove) why it appears appropriate in the specific case to subject the order or measure to security pursuant to R. 118.8 RoP. It is then incumbent on the claimant to contest these facts on reasonable grounds, especially as the claimant usually has knowledge and evidence of his financial situation. In addition, it is the plaintiff's responsibility to explain and justify (and, if necessary, provide evidence) why, despite the reasons put forward by the defendant, his interest in the enforceability of the order or measure without the provision of security outweighs the defendant's interest (see Düsseldorf Local Chamber, decision of 31 October 2024, UPC_CFI_373/2023, p. 26; Mannheim Local Chamber, decisions of 11 March 2025, UPC_CFI_373/2023, p. 26). 11 March 2025, UPC_CFI_159/2024, UPC_CFI_162, para. 132 and 137 - Hurom ./ NUC Electronics and others).

134. In the case in dispute, nothing has been submitted to jeopardise the enforcement of any claims for damages in the event that the judgement is subsequently set aside and nothing else is apparent.

F. Decision on costs

135. The decision on costs is based on Art. 69(1) UPCA, R. 118.5 RP. Since the action is largely successful and the action for revocation is unsuccessful, the panel exercises its discretion to order the defendants to pay the costs of the proceedings in full. The unsuccessful claim against defendants 2 and 3 in addition to defendant 1 as their managing director is not significant. In particular, it is not apparent that it would be of economic significance in addition to the claim against defendant 1. According to Annex LS 1, Defendant 2 is the founder of Defendant 1 and Defendant 3 is his son. In this situation, there was no serious possibility from the outset that the defendants 2 and 3 could commit patent infringing acts outside of their activities at the defendant 1 as their family business, so that the action against the defendants 2 and 3 is not to be attributed any significant economic importance of its own. It is also not apparent that the defendants 2 and 3 would have incurred significant expenses of their own, which

they would not be reimbursed by defendant 1. In the absence of any evidence to the contrary, it must rather be assumed that Defendant 1 also bears the legal defence costs of Defendants 2 and 3 in the internal relationship because claims are asserted against them in their capacity and on the basis of their activities as their managing directors.

G. Value in dispute

1. The plaintiff has stated the value in dispute for the infringement action at EUR 1,500,000. In the absence of better information, the Chamber therefore sets the value in dispute for the infringement action and the action for cancellation at EUR 1,500,000 each, i.e. the amount in dispute for the overall proceedings at EUR 3,000,000. An increase in the amount in dispute for the action for cancellation compared to the action for infringement was not appropriate. There is no apparent economic significance that goes significantly beyond the present proceedings and would justify a total amount in dispute of more than EUR 3,000,000.

ORDER:

- I.
 1. Defendant 1 is ordered to refrain from manufacturing, offering, placing on the market, using or importing or possessing a product with the following features for the aforementioned purposes in the territory of the UPCA contracting member states Germany, Austria and Luxembourg:

Edging for flower beds and grassland areas consisting of at least two sheet metal strips which can be joined together at the ends, which are flanged at least on the upper longitudinal side and form connecting ends (2, 3) in the region of their ends, which are inserted into one another in an overlapping manner, one connecting end being designed as a tongue (4), which engages in a receiving slot (16) arranged in the opposite connecting end, characterised in that a receiving slot (16) arranged in the beading of one connecting end (3) can be plugged onto the tongue (4) at the other connecting end (2) in a direction perpendicular to the longitudinal extent of the sheet metal strip (6).
 2. Defendant 1 is ordered, at its own expense
 - a. to recall the products according to item 1 from the distribution channels;
 - b. to permanently remove the products according to item 1 from the distribution channels;
 - c. to destroy the products pursuant to No. 1.
 3. Defendant 1 is ordered to provide the plaintiff with information about

- a. the origin and distribution channels of the products pursuant to no. 1 and
 - b. the quantities produced, manufactured, delivered, received or ordered and the prices paid for the products referred to in Clause 1 and
 - c. the identity of all third parties involved in the manufacture or distribution of the products referred to in Clause 1.
4. It is established that defendant no. 1 must compensate the plaintiff for all damages that it has suffered and will suffer as a result of the actions pursuant to no. 1.
 5. In all other respects, the action for infringement is dismissed.
 6. A penalty payment of up to EUR 250,000 is threatened for each case of infringement by defendant 1 against the orders and measures pursuant to items 1 to 3.
- II. The action for annulment brought by Defendant 1 is dismissed.
 - III. The defendants shall bear the costs of the legal dispute.
 - IV. The value in dispute is set at EUR 3,000,000.

Issued in Mannheim on 12 September 2025

NAMES AND SIGNATURES

Presiding Judge Prof Dr Tochtermann	<p>(Peter) (Michael) Dr Tochtermann</p> <p>Digitally signed by Peter Michael Dr. Tochtermann Date: 2025.09.11 16:30:44 +02'00'</p>
Legally qualified judge Böttcher	<p>(Dirk) (Andreas) Böttcher</p> <p>Digitally signed by Dirk Andreas Böttcher Date: 2025.09.05 16:44:56 +02'00'</p>
Legally qualified judge Kupecz	<p>András Ferenc Kupecz</p> <p>Digitally signed by András Ferenc Kupecz Date: 2025.09.07 15:01:15 +02'00'</p>
Technically qualified judge Tilmann	<p>(Max) (Wilhelm) Tilmann</p> <p>Digitally signed by Max Wilhelm Tilmann Date: 2025.09.06 13:44:03 +02'00'</p>
For the Assistant Registrar: Kranz, Clerk LK Mannheim	<p>(ANDREAS] (MICHAEL) (Kranz)</p> <p>Digitally signed by ANDREAS MICHAEL Kranz Date: 2025.09.11 16:48:14 +02'00'</p>

Information on the appeal:

An appeal against the present decision may be lodged with the Court of Appeal by any party whose requests have been unsuccessful in whole or in part within two months of notification of the decision (Art. 73(1) UPCA, R. 220.1(a), 224.1(a) RP).

Information on enforcement (Art. 82 UPCA, Art. Art. 37(2) UPCA, R. 118.8, 158.2, 354, 355.4 RP):

A certified copy of the enforceable decision is issued by the Deputy Registrar at the request of the enforcing party, R. 69 RegR.