



**UNIFIED PATENT COURT COURT OF FIRST
INSTANCE LOCAL DIVISION OF MILAN**

**UPC CFI No. 802/2024
Decision filed on 19
November 2025**

HEADNOTES

1. Pursuant to the combined provisions of Article 37 UPCS and Rules 277 and 355 RoP, three essential conditions must be verified in order to issue a decision in default:

- verification of the regularity of the service of the writ of summons, in accordance with the conditions set out in detail in Rule 277 RoP;
in detail in Rule 277 RoP;
- failure by the defaulting party to comply with a time limit laid down in the rules or set by the Court;
- The facts presented by the plaintiff must justify the measures requested, and the defendant's pro-sexual conduct does not prevent such a decision from being issued.
of the defendant does not prevent such a decision from being issued.

2. Pursuant to Rule 271 RoP, the writ of summons may be validly served on the defendant even without the annexes indicated and referred to therein, provided that the content of the document instituting the proceedings allows the defendant to fully understand the facts of the case, with the consequent possibility of asserting their rights in proceedings pending before the Unified Patent Court. In fact, in general, the annexes have an evidentiary function and are not indispensable for understanding the *cause of action and the relief* sought and, as such, do not form an integral part of the document instituting the proceedings within the meaning of EU Regulation No 1784/2020 and Rule 271 RoP.

3. Rule 171.2 RoP incorporates the general principle of non-contestation of specific facts, with the procedural effect of considering uncontested facts to be acknowledged and therefore proven. The burden of specific contestation can only be placed on the party that has chosen to actively exercise its right of defence in the proceedings, and not on the defaulting party that remains absent from the proceedings for various reasons - which there is no reason to investigate or ascertain - without prejudice to the need to always verify that the defaulting party

has been duly informed, in accordance with the law, of the existence of the proceedings

Contumacy therefore remains a neutral procedural circumstance, in respect of which it is nevertheless permissible - under certain specified conditions - to adopt a decision because the absence of the defendant cannot allow the proceedings to be paralysed *indefinitely* and the plaintiff's expectations of protection to be frustrated.

4. Rule 355.2 RoP helps to define the standard of proof that must be met by the claimant in order for a decision to be made in absentia, in conjunction with the general principle established by Article 54 UPCA, excluding the possibility of automatic acceptance of the claim due to the defendant's failure to appear and therefore solely on the basis of the mere assertions of one of the parties. The facts on which the claim is based must be proven, as established by Article 54 UPCA, and, as such, must be sufficient to justify the adoption of the requested measures.

KEYWORDS

decision by default, service of the writ of summons, burden of proof for the adoption of a decision in absentia
decision *in absentia*

PLAINTIFFS

- 1) MORELLO FORNI ITALIA S.R.L. - via Bartolomeo Parodi 35, 16014, Ceranesi (GE), Italy
- 2) MORELLO FORNI S.A.S. DI MORELLO MARCO & C. - via Bartolomeo Parodi 35, 16014, Ceranesi (GE), Italy

represented and defended by lawyers Vittorio Cerulli Irelli and Lorenzo Battarino, and by Dr. Pierluigi Carbonara

DEFENDANTS

- 1) GASTROTEAM ABBE AB - Mekanikervägen 6, 564 35, Bankeryd, Sweden
- 2) SALVATORE MARCIULIANO, owner of the sole proprietorship MARCIULIANO ATTREZZA-TURE - via Montegrappa 15, 75012, Bernalda (MT), Italy

PATENT SUBJECT TO DISPUTE

EP 3691454 B1 (hereinafter EP'454) entitled *Method and apparatus for shaping pizza dough*

DECIDING JUDGE

This decision is adopted by the Panel composed of the following members:

- Pierluigi PERROTTI presiding judge and judge rapporteur
- Alima ZANA judge qualified in legal matters
- Samuel GRANATA judge qualified in legal matters

LANGUAGE OF THE PROCEEDINGS

Italian

SUBJECT MATTER OF THE PROCEEDINGS

Action for infringement of patent

1. Summary of the facts of the case

Morello Forni s.a.s. di Morello Marco & C. (hereinafter Morello) and Morello Forni Italia s.r.l. (hereinafter Morello Italia) are, respectively, the owner and licensee of EP'454. The patent in question protects a method for shaping pizza dough and a machine for implementing it. Morello holds 100% of the shares in Morello Italia. The machine is marketed under the registered trademark *Pizzarella*.

With a statement of claim filed on 13 December 2024, the plaintiffs brought proceedings before the Unified Patent Court, Court of First Instance, Local Division of Milan, against the Swedish company Gastroteam Abbe AB (hereinafter Gastroteam) and Salvatore Marciuliano, owner of the sole proprietorship Marciuliano Attrezzature (hereinafter Marciuliano), with registered office in Italy, and stated the following.

During 2018, Gastroteam had assumed the role of exclusive distributor for Sweden of the *Pizzarella* machine. The commercial collaboration had been interrupted. Subsequently, without prior authorisation from the plaintiffs, Gastro-team began to manufacture, offer for sale and distribute throughout Europe a machine called *Pizza Former or Pizzapress or even Pizzaform* (hereinafter, for greater clarity, always referred to as *Pizza Former*), which reproduced all the features claimed in EP'454.

Marciuliano operated as a local distributor for Gastroteam, offering the *Pizza Form* machine for sale in Italy.

The plaintiffs concluded by requesting a finding of patent infringement, with the consequent issuance of injunctions, withdrawal from the market and destruction of counterfeit products, communication of all commercial information useful for understanding the origin and extent of the unlawful conduct, publication of the decision, with the defendants ordered to pay provisional damages and subject to separate proceedings for compensation for damages and reimbursement of legal costs.

The statement of claim was served on Marciuliano on 8 January 2025 and on Gastroteam on 17 March 2025.

The defendants did not access the file through a representative, nor did they file a statement of defence or other written defence.

On 8 July 2025, the plaintiffs filed a request for a default judgment *pursuant to* Article 37 of the UPCS and Rule 355 of the RoP.

2. Requests of the parties

The plaintiffs request that the Milan Local Division of the Unified Patent Court, rejecting and disregarding any contrary request, claim, objection or counterclaim, rule as follows:

primarily:

rolling on its intrados (45a); wherein the rollers (21, 22) are adapted to make a motion of revolution about an axis (Y) substantially perpendicular to the diaphragm (45); said motion of revolution being cyclically at time intervals clockwise and counterclockwise about said axis (Y); or alternatively a

5. Machine according to claim 4, wherein the diaphragm (45) comprises at least one extrados layer (45b) in contact with the dough, made of food-grade low-friction plastic material; or alternatively a

6. Machine according to claim 5, wherein the diaphragm (45) is a two-component or multi-component one, and comprises at least one said intrados layer (45a) made of a material different from that of the extrados layer (45b); or alternatively a

7. Machine according to claims 5 or 6, wherein the material of the extrados layer (45b) comprises polytetrafluoroethylene (PTFE), while the material of the intrados layer (45a) comprises silicone or another material having a high coefficient of friction; or alternatively a

8. Machine according to any one of claims 4 to 7, wherein the diaphragm (45) is fixed to a worktable (40) and its extrados surface (45b) protrudes from said table by a predefined difference in level (S); or alternatively a

9. Machine according to any of claims 4 to 8, wherein the rollers (21, 22) are idle; or alternatively a

10. Machine according to any one of claims 4 to 9, wherein the tapered rollers (21, 22) comprise an edge (21b, 22b) rounded at the base; or alternatively, a

11. Machine according to any one of claims 4 to 10, wherein said intrados layer (45a) is made of or coated with silicone-based material, rubber-based material or another material having a high coefficient of friction; or alternatively a

12. Machine according to any one of claims 4 to 11, wherein the plate (50) comprises a face or surface (55) in contact with the dough, at least partly made of food-grade non-stick material; or alternatively a

13. Machine according to claim 12, wherein the contact surface (55) of the plate (50) has a profile that is substantially flat at the centre and slightly raised along a peripheral band (55a) near the outer edge; or alternatively a

14. Machine according to any one of claims 4 to 13, wherein the plate (50) is supported by an articulated arm (3), which can be actuated manually and/or automatically in order to move the plate (50) into said operating and idle positions; 67

or alternatively a

15. Machine according to claim 14, wherein the articulated arm (3) comprises an articulated quadrilateral structure (301, 302, 303, 510, 511, 520, 521) adapted to hold the plate (50) in a condition substantially parallel to the diaphragm (45) during the translations between said operating and idle positions, and vice versa;

or alternatively a

16. Machine according to claims 14 or 15, wherein the plate (50) comprises a fitting (53) for connecting to the arm (3), and a crown (500) adjustably associated with the fitting (53);

or alternatively a

17. Machine according to claim 16, wherein the crown (500) is associated with the fitting (53) by means of a threaded connection (502, 505), which allows for fine adjustment of the distance between the bottom face (55) of the plate (50) and the diaphragm (45) when the plate is in the lowered operating condition;

or alternatively a

18. Machine according to any one of claims 4 to 17, wherein the plate (50) is supported by an articulated arm (3), which can be actuated manually and/or automatically in order to move the plate (50) into said operating and idle positions, comprising a handle (54) or the like for actuating the articulated arm (3), positioned in such a way that the articulated arm (3) will substantially form a second-order lever with respect to a dough (I) to be worked;

2) inhibit pursuant to Articles 25, 26 and 63 UPCA, permanently and with immediate effect from the moment of notification of the judgment pursuant to Article 82.1 UPCA, and Rules 118.8, 350.2 and 354.1. RoP - with reference to all 18 countries that have ratified the Agreement on the Unified Patent Court (UPCA) - to the defendant Gastroteam Abbe AB and the defendant Marciuliano Attrezzature di Marciuliano Salvatore any form of production, marketing, advertising, distribution, import, export, storage, offering in any form, direct or indirect, as well as any coordination activity carried out for this purpose by the defendants, including directly or indirectly through their agents, employees, distributors, staff, officers, affiliates or other controlled entities, in relation to the machine identified as *Pizza Former or Pizzaformer*, but also *pizzapress, pizzaform*, and which uses the registered trademarks *Saliba Former and 2North*, or otherwise named, as well as any machine for rolling out pizza bases and other foods that has the characteristics claimed by patent EP 3691454 owned by Morello Forni s.a.s. di Morello Marco & C. and in particular that reproduces the characteristics claimed by at least

one of claims 1 to 18 of EP 3691454 reproduced above, and in any case covered by the ruling on infringement under 1);

3) order, pursuant to Article 64 of the UPCA, the defendants Gastroteam Abbe AB and Marciuliano Attrezzature di Marciuliano Salvatore to carry out, at their own expense and within 30 days of notification of the judgment, the recall and withdrawal of the counterfeit products referred to in claims 1) and 2) from any sales channel on the market, as well as all related commercial and promotional/advertising material, both physical and online;

4) order, pursuant to Article 64 UPCA, the defendants Gastroteam Abbe AB and Marciuliano Attrezzature di Marciuliano Salvatore to permanently destroy the counterfeit products referred to in claims 1) and 2), as well as all related commercial and promotional/advertising material, both physical and online, at their own expense and within 30 days of notification of the judgment;

5) order, pursuant to Article 67 UPCA, the defendant Gastroteam Abbe AB and the defendant Marciuliano Attrezzature di Marciuliano Salvatore to provide Morello, in digital format and structured in such a way as to allow for prompt consultation, within 30 days of notification of the judgment, all information relating to:

a) the origin and distribution channels of the *Pizzaformer* machine at issue;

b) the quantities produced, manufactured, supplied, received or ordered of the machine in question, as well as the turnover generated by its sale; and

c) the identity and details of any third parties involved in the production or distribution of the counterfeit machine in question,

and ordering the defendants to provide, in the same manner, copies of all accounting, tax and commercial information relating to the extent of the counterfeiting phenomenon, as well as their accounting records relating to the sale of the counterfeit machine, pursuant to Article 59.2 UPCA and Rule 141 RoP, and also for the purpose of verifying the accuracy of the above information, including, by way of example, the following information and documentation:

a. all invoices - or, in the absence thereof, all delivery notes - journals, inventory books, VAT registers, warehouse loading and unloading registers, also providing summary information indicating the quantities sold, broken down by period, the prices of the goods and the names of the models, as well as the names and addresses of the commercial recipients of the offers for sale for all products sold or otherwise transferred;

b. all invoices, customs and import documents, T1 declarations for external Community transit, T2 declarations for internal customs transit, INTRASTAT forms (summary of intra-Community trade in goods) for all products sold, as well as for products purchased (thus allowing the purchase data for counterfeit machines to be cross-referenced with the relevant sales data);

c. evidence of advertising and promotional activities carried out, breaking down the activities carried out according to the means used, their dissemination, the period of distribution and the territory of distribution;

d. evidence of costs incurred, broken down by individual cost factors and profits made;

e. invoices - or, in the absence of these, delivery notes - and related invoices for all costs incurred on which the defendants rely to calculate their profits;

6) order, pursuant to Article 80 of the UPCA, the publication of the forthcoming decision for a reasonable period of time following the decision and in such a way as to ensure that the market is effectively aware of it, ordering in particular the publication of the judgment in full on the websites of the defendant Gastroteam <https://gastroteam.se> and <https://sali-baequipment.com>, and the defendant Marciuliano <https://www.marciulianoattrezzature.it>, with an English translation for Gastroteam and, in any case, with a prominent reference at the top of the homepage for a period of at least six months, as well as, at the request of the plaintiffs and at the expense of the defendants, in *Il Sole24Ore* and in the following trade magazines:

- *France pizza* - <https://www.francepizza.fr>;
- *Pizza & Pasta* - <https://www.pizzaepastaitaliana.it>;
- *Ristorazione Italiana* - <https://www.ristorazioneitalianamagazine.it>;
- *Ristorando* - <https://www.ristorando.eu>;
- *foodservice* - <https://www.food-service.de>;

7) order pursuant to Articles 63.2 and 82.4 UPCA to the defendant Gastroteam Abbe AB and the defendant Marciuliano Attrezzature di Marciuliano Salvatore to pay periodically a fair sum as a penalty in the event that they do not comply with the measures taken by the Court in its ruling, quantifiable at €20,000 per unit for each violation of the injunction, and €5,000 for each day of delay in the execution of any of the measures taken;

8) ascertain and declare, pursuant to Rule 118.1 RoP, that the defendant Gastroteam Abbe AB and the defendant Marciuliano Attrezzature di Marciuliano Salvatore shall be required to pay Morello the entire amount of damages, which shall be quantified in separate proceedings pursuant to Rules 125 et seq. RoP;

9) order, pursuant to Rule 119 RoP, the defendant Gastroteam Abbe AB and the defendant Marciuliano Attrezzature di Marciuliano Salvatore to pay Morello a provisional sum of €100,000 or such other sum as may be deemed appropriate in the course of the proceedings;

10) ascertain and declare, pursuant to Rule 118.5 RoP, that the defendant Gastroteam Abbe AB and the defendant Marciuliano Attrezzature di Marciuliano Salvatore shall be required to reimburse Morello in full for all costs and expenses relating to the present proceedings, to be settled in subsequent proceedings to be instituted pursuant to Rules 150 et seq. RoP.

In the alternative:

11) in the event that the defendants contest the reconstruction of the characteristics and functionality of the *Pizzaformer* machine proposed by the plaintiffs, pursuant to Article 59.1 UPCA, order the defendants, at the earliest opportunity during the present proceedings, to provide the plaintiffs with a copy, in digital format and structured in such a way as to allow for prompt consultation, of all technical documentation (such as, for example, manuals, diagrams, technical and construction drawings) relating to the machine identified as *Pizza Former or Pizzaformer*, but also *pizzapress*, *pizzaform*, and which uses the registered trademarks *Saliba Former and 2North*, or otherwise named, as well as to make a sample of this machine available to the plaintiffs and the Court for examination.

Subject to bringing separate proceedings for the settlement of the expenses and costs incurred by the plaintiffs pursuant to rules 150 et seq. RoP, as well as bringing separate proceedings for the settlement of the damages suffered by the plaintiffs pursuant to rules 125 et seq. RoP.

3. Requirements for issuing a default judgment pursuant to Article 37 of the UPCS.

Article 37 UPCS provides that, at the request of one party to a case, a decision may be issued in absentia in accordance with the rules of procedure if the other party, after receiving notification of the writ of summons or equivalent document, fails to file written submissions in its defence or fails to appear at the hearing.

Rule 355 RoP provides that "upon request, a decision by default may be given against a party where: (a) the Rules of Procedure so provide if a party fails to take a step within the time limit foreseen in these Rules or set by the Court; or (b) without prejudice to Rules 116 and 117, the party which was duly summoned fails to appear at an oral hearing. 2. A decision by default against the defendant of the claim or counterclaim may only be given where the facts put forward by the claimant justify the remedy sought and the procedural conduct of the defendant does not preclude giving such a decision.

Finally, Rule 277 RoP additionally specifies that 'no decision by default shall be entered under Part 5, Chapter 11 (*Rules 355 et seq. RoP*) unless the Court is satisfied that either:

(a) the Statement of claim was served by a method prescribed by the internal law of the state addressed for the service of documents in domestic actions upon persons who are within its territory; or (b) the Statement of claim was actually served on the defendant under this Chapter 2”.

In the present case, according to the combined provisions of the rules referred to above, three essential conditions must be verified for the issuance of a default judgment:

- verification of the regularity of the service of the writ of summons, in accordance with the conditions set out in detail in Rule 277 RoP;

- the defaulting party's failure to comply with a time limit laid down in the rules or set by the Court;
- the facts presented by the plaintiff must justify the measures requested and the defendant's conduct in the proceedings must not prevent such a decision from being issued.

4. Service of the writ of summons

The statement of claim was served on Gastroteam by post, with the package being received and collected on 17 March 2025. This is confirmed by the results of the Italian Post Office's online shipment tracking service and by the defendant's express declaration that the writ of summons was received on 17 March 2025. The declaration was made on 1 June 2025 by ■ Gastroteam, who has the power to sign and represent the company, as shown in the certificate of registration from the Swedish Companies Registration Office, extracted on 31 October 2024 (see doc. 6).

The legal representative of the Swedish company signed the following statement, written in Italian: *"Case number 65927/2024, sent to us by the competent court, was received on 17 March 2025. [...] Before going into the details of our response, we would like to point out that we reject all unfounded allegations of counterfeiting and patent infringement in general terms in the writ of summons filed with your court by Morello Forni Italiana SRL and Morello Marco & C. S.A.S. through their official lawyers on 13/12/2024"*. The number 65927/2024 uniquely identifies this proceeding, according to the progressive numbering used with the old Case Management System, and corresponds to UPC CFI case no. 802/2024. If that were not enough, there is a further unequivocal reference to the writ of summons filed by the plaintiffs on 13 December 2024, with perfect correspondence of subjects and dates.

There is therefore certain and direct confirmation of the actual receipt of the statement of claim by the defendant Gastroteam on 17 March 2025.

In entirely similar terms, proof is also provided of the notification on 8 January 2025 of the writ of summons to Marciuliano, sent by certified email, extracted from the public database of the Register of Companies (see doc. 31).

In this case too, on 11 January 2025, the clerks of the Sub Registry of the Milan Local Division received explicit confirmation of delivery. This communication was forwarded via the same certified email address of Marciuliano used for the notification of the summons, in direct reply to the message of 8 January 2025 transmitting the copy of the statement of claim.

Marciuliano's conduct leaves no doubt as to his actual knowledge of the existence of these proceedings, which are also pending against him.

In addition to the above considerations, which are in themselves sufficient to prove the successful outcome of the notification, the conditions set out in Rule 277.1 (a)(b) RoP have also been met in all cases for both defendants.

With regard to Gastroteam, the statement of claim was served in accordance with Article 18 of EU Regulation No. 1784/2020, under which it is possible to serve or communicate judicial documents to persons present in another Member State of the European Union directly by post, by registered letter with acknowledgement of receipt or by equivalent means.

As for Marciuliano, it is a sole proprietorship based in Italy and the notification of the summons was carried out using a method provided for by Italian law for the notification of judicial documents.

On this point, it is sufficient to note that:

- an electronic address registered with a certified email service constitutes a digital domicile, pursuant to and for the purposes of Article 1, paragraph 1, letter *n-ter*) of Legislative Decree No. 82/2005, as last amended by Legislative Decree No. 217/2017, and is therefore to be considered valid for the purposes of electronic communications with legal value;
- Article 16, paragraph 6, of Decree Law No. 185/2008 imposed on all companies incorporated as corporations the obligation to adopt a digital domicile¹;
- Article 5, paragraph 2, of Decree Law No. 179/2012 then extended the obligation to adopt a digital domicile to all sole proprietorships².

Finally, it is entirely irrelevant that the documents referred to in the writ of summons were not attached to the notification. Pursuant to Rule 271 RoP, the writ of summons may be validly served on the defendant even without the attachments indicated and referred to therein, provided that the content of the writ of summons allows the defendant to fully understand the facts of the case and consequently to assert their rights in proceedings pending before the Unified Patent Court (see UPC CoA No. 320/2023, 13.10.2023; UPC CFI No. 412/2023, 16.9.2024 - CD Paris). In fact, in general, annexes have an evidentiary function and are not indispensable for understanding the *cause* of action *and the relief* sought and, as such, do not form an integral part of the document instituting the proceedings within the meaning of EU Regulation No. 1784/2020 and Rule 271 RoP.

¹ *"Companies incorporated as corporations are required to indicate their digital domicile as referred to in Article 1, paragraph 1, letter n-ter), of Legislative Decree No. 82 of 7 March 2005. By 1 October 2020, all companies already incorporated as companies shall communicate their digital domicile to the Companies Register if they have not already done so."*

² *"The obligation referred to in Article 16, paragraph 6, of Decree-Law No. 185 of 29 November 2008 [...] is extended to sole proprietorships that apply for initial registration in the register of companies or the register of craft businesses after the date of entry into force of the law converting this decree. [...] Sole proprietorships that are active and not subject to insolvency proceedings and have not already indicated their digital domicile to the competent Companies Register are required to do so by 1 October 2020."*

In the present case, the statement of claim contains all the information necessary to provide the defendants with a full understanding of what is being claimed and requested of them.

5. Failure to comply with the deadline for filing the statement of defence

The defendants did not access the case file through a representative, nor did they file a statement of defence (or other written defence) within the time limits set out in the rules of procedure.

6. The facts presented by the claimant justify the measures requested

As already clarified by a previous decision of this Court (see UPC CFI No. 513/2024, 8.7.2025 - CD Milano), in the case of a defendant in default, rule

171.2 RoP cannot be applied. The latter provision incorporates the general principle of non-contestation of specific facts, with the procedural effect of considering uncontested facts to be acknowledged and therefore proven.

However, it is clear that the burden of specific contestation can only be placed on the party that has chosen to actively exercise its right of defence in the proceedings, and not on the defaulting party who remains absent from the proceedings for various reasons - which there is no reason to investigate or know - without prejudice to the need to always verify that the defaulting party has been duly informed, in accordance with the law, of the existence of the proceedings.

Contumacy therefore remains a neutral procedural circumstance, in relation to which it is nevertheless permissible – under certain specified conditions – to adopt a decision, because the absence of the defendant cannot allow the proceedings to be paralysed *indefinitely* and the plaintiff's expectations of protection to be frustrated.

Rule 355.2 RoP contributes to defining the standard of proof that must be met by the claimant in order for a decision to be made in default, in conjunction with the general principle established by Article 54 UPCA, excluding the possibility of automatic acceptance of the claim as a result of the defendant's default and therefore solely on the basis of the mere assertions of one of the parties. The facts on which the claim is based must be proven, as established by Article 54 UPCA, and, as such, must be sufficient to justify the adoption of the measures requested.

Having said that in general terms, the Court considers that in the present case this requirement is also satisfied, on the basis of the following considerations.

7. The patent at issue

Morello is the owner of EP'454, entitled '*method and apparatus for shaping pizza dough*'. The application for the patent was filed on 26 September 2018, claiming priority from Italian patent application IT 201700111949 dated 5 October 2017. The patent was granted on 17 July 2024. On the same date, the plaintiff filed a request for unitary effect, which was granted on 2 September 2024. The patent is therefore effective in all 18 Contracting Member States that have currently ratified the Agreement on the Unified Patent Court.

No oppositions were filed before the EPO.

It is not necessary to carry out any investigation or consideration of the invalidity of the patent, as the Court has no power to raise the issue *ex officio*, even in a default judgment. It is also well known that, according to the case law of the Court of Justice (see C-44/21, Phoenix Contact GmbH & Co. KG, para. 41), '*European patents enjoy a presumption of validity from the date of publication of their grant*'.

The patent includes 18 claims: independent claim 1 for the method and independent claim 4 for the apparatus. Claims 2 and 3 are dependent on claim 1, and claims 5 to 18 are dependent on claim 4.

This is the text of claim 1:

- 1.1. Method of forming food doughs for making bases for pizza and the like, comprising the operational steps of:
- 1.2. (a) compressing a predefined mass of dough (I) to be worked [...] between two surfaces (45, 50)
- 1.3. [in the usual loaf or bubble form];
- 1.4. (b) rolling the compressed dough (I) through at least one of said surfaces (45)
- 1.5. to generate periodic pressure waves within its mass;
- 1.6. wherein the pressure waves extend radially relative to the shape of the base to be made;
- 1.7. wherein the pressure waves rotate relative to the mass of dough (I);
- 1.8. wherein the pressure waves rotate in alternate cycles.

Claim 4 provides as follows:

- 4.1. a machine for implementing the method according to any one of the preceding claims, comprising:
- 4.2. a dough supporting diaphragm (45), which is at least partially deformable;
- 4.3. a cover or plate (50) adapted to be moved between
- 4.4. an idle position, in which it is raised above the diaphragm (45), and
- 4.5. an operating position, in which it is set against the diaphragm (45), so as to compress a mass of dough (I) to be worked [...] laid thereon, and vice versa;

- 4.6. [in the usual loaf or bubble form,]
- 4.7. means (21, 22, 31, 33, 35) for deforming the diaphragm (45),
- 4.8. operating on that side of the latter which is opposite to the side whereon the dough (I) has been laid,
- 4.9. thereby causing pressure waves that extend radially relative to the shape of the base to be made;
- 4.10. wherein the means for deforming the diaphragm (45) comprise tapered rollers (21, 22) that operate by rolling on its intrados (45a);
- 4.11. wherein the rollers (21, 22) are adapted to make a motion of revolution about an axis (Y) substantially perpendicular to the diaphragm (45);
- 4.12. said motion of revolution being cyclically at time intervals clockwise and counterclockwise about said axis (Y).

The descriptive part of the patent clarifies that the manual processing of pizzas requires a certain skill and manual dexterity, which are usually the prerogative of expert pizza makers who perform this task professionally, and inevitably requires a certain amount of time. Furthermore, the processing of dough by hand depends on the human operator, with performance varying from person to person and also varying from moment to moment depending on the circumstances ([0007]-[0010]).

If, on the other hand, the dough is processed using mechanised tools, the times can be reduced, but this has the disadvantage of putting greater chemical and physical stress on the dough, with the risk of altering its organoleptic characteristics and therefore the quality of the product obtained ([0011]).

Machines have been developed for the automated (or semi-automated) processing of dough and the production of pizza bases, essentially of two types ([0013]-[0016]):

- a) presses that crush the dough between two flat surfaces, causing it to reduce in thickness and expand radially at the same time, according to the desired disc configuration;
- b) laminators comprising two motorised rollers, positioned opposite each other at a distance that allows the dough to pass between them. In this case, a strip of dough of the desired thickness is obtained. If a round pizza base is required, the dough must then be further shaped, with an additional processing stage, inevitably increasing production times and costs. Furthermore, the rolling of the dough by the rollers generates mechanical stress in the dough mass, which can deteriorate or otherwise alter it, negatively affecting the final product.

The solution claimed by EP'454 aims to solve the problems described, providing ([0032]-[0033]):

- a) the shaping of the dough by acting on it indirectly, i.e. by placing a flexible element between the dough and the means (conical rollers) that exert the pressure necessary for its rolling, along radial lines with respect to the shape to be obtained; and at the same time
- b) processing the dough in alternating cycles, i.e. periodically reversing the direction of the pressure exerted on the dough. This avoids direct contact between moving mechanical parts and the dough and ensures that the pressure is distributed more evenly in space and time.

The forming machine comprises a base or pedestal 2 surmounted by an articulated arm 3 (see Fig. 1 below). The base 2 has an external structure 10 substantially in the shape of a parallelepiped or box, equipped with support feet 11; the external structure 10 is made of sheet metal or any other suitable material (e.g. plastic or similar) and serves, among other things, as a housing for a manipulator mechanism 20 for the dough to be formed.

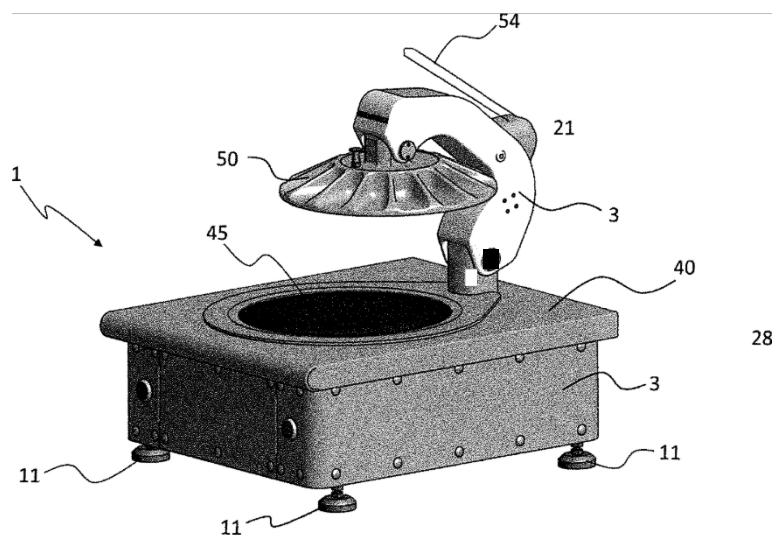

Fig. 1

The manipulator mechanism 20 comprises at least one pair of conical rollers 21, 22, with competing axes and inclined with respect to the working plane of the machine 1, so as to have respective horizontal generatrices, identified with the numbers 21a and 22a in Fig. 6 reproduced below, aligned along a diameter ([0042-0043]).

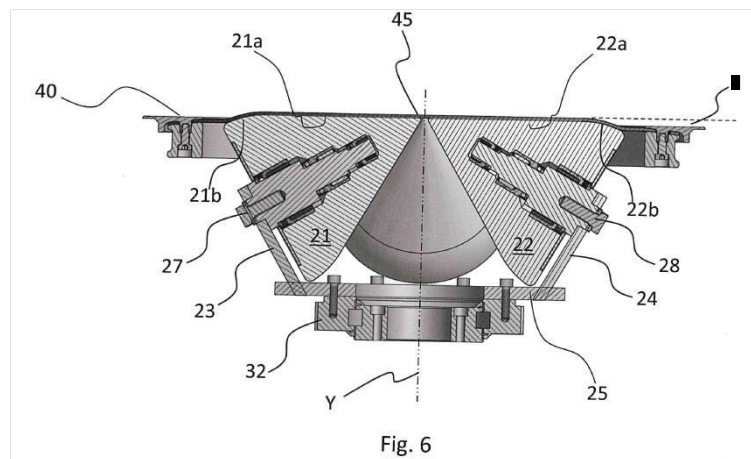

Fig. 6

In accordance with a preferred embodiment, the conical rollers 21, 22 have a rounded edge or corner 21b, 22b at the base (see immediately below, Fig. 12), so that the membrane 45 adhering to them has an inclined profile in the peripheral area connecting with the work surface 40 ([0059]). This allows the creation of a thickened edge (cornice) on the pizza bases, without interrupting the dough rolling process.

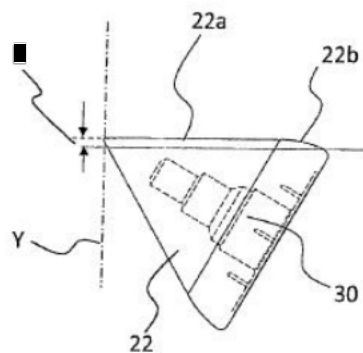

Fig. 12

Rollers 21 and 22 are idly supported by respective arms 23 and 24, which extend divergently from a turntable or platform 25 rotating around a vertical axis Y. The turntable 25, by means of appropriate transmission and drive means, including an electric motor, is rotated on its axis, which in turn causes the conical rollers to revolve along the same Y axis.

In turn, the means for driving the turntable 25 are designed to reverse the rotational movement around the vertical axis Y in both directions (clockwise or anticlockwise) of the assembly comprising the turntable and conical rollers 21, 22 ([0050]).

The reversal of the rotary movement of the turntable (and therefore of the conical rollers integral with the turntable) is controlled by the machine's control system and occurs cyclically at predetermined intervals and/or selected by a user of the machine.

The base 2 of the machine also includes an upper work surface 40, on which a mixture I to be processed is placed. More specifically, the work surface 40 has a circular central opening 41, closed by a membrane 45, at which point the horizontal generatrices 21a, 22a of the conical rollers 21, 22 emerge; the membrane 45 is secured to the work surface 40, keeping it at a predetermined tension so that it adapts to the conical rollers 21, 22 below and at the same time maintains a flat surface for processing dough (see [0057] et seq.).

The machine developed by Morello operates according to the following steps:

- the operator places a typical ball or preformed loaf of dough on the lower work surface, consisting of a deformable plastic membrane;
- the operator lowers the lever that activates the articulated arm, which brings the upper plate into contact with the dough, pressing it against the membrane;
- a mechanism of multiple conical rollers located below the membrane is automatically activated and, acting indirectly on the dough through the membrane with a revolving motion of the conical rollers, causes the formation of periodic pressure waves within the dough which - working synergistically with the pressure exerted by the upper plate - cause it to expand from the centre outwards, in a radial direction, until it reaches the desired size of the circular pizza base disc;
- In this context, the cyclical reversal of the direction of rotation of the conical rollers with respect to the relative vertical axis Y is advantageous, as it allows for an action equal and opposite to that of the previous cycle, thus ensuring uniformity in the spreading of the mixture.
- the rounding of the cones near their base (see Fig. 12 reproduced above) corresponds to a decrease in the forming action with a relative accumulation of dough

previously carried to that area by the active sections closest to the centre or axis of rotation ([0123]) and, together with the shape of the lower face of the plate, makes it possible to create the thickened edge (cornice) of the pizza base without interrupting the dough processing process;

- the operator then raises the lever that activates the articulated arm, causing the conical rollers to stop automatically, returning the upper plate to its resting position and allowing the formed pizza base to be removed.

8. Reproduction of the characteristics claimed by the patent in question.

The plaintiffs have adequately demonstrated the actual presence in the *Pizza Former* machine of all the features indicated in the patent claims, with the sole exception of those contained in claims 7 and 11, relating to the use of certain types of materials, for which there is insufficient certainty as to their actual use in certain components of the *Pizza Former* machine.

The plaintiffs have attached a detailed report to the case file (see doc. 47), which documents the results of the technical analysis carried out on a model of the *Pizza Former* machine found at a pizzeria in Giussano (MB) - Italy. This model was sold by Marciuliano on 1 August 2024 (see doc. 33a - d).

A complete examination of the presence of the individual characteristics is carried out below.

1.1 Method of forming food doughs for making bases for pizza and the like, comprising the operational steps of:

It is clear from the documents that the *Pizza Former* machine is designed for forming food doughs to make bases for pizza and the like.

1.2 (a) compressing a predefined mass of dough (I) to be worked [...] between two surfaces (45, 50);

1.3 [in the usual loaf or bubble form,];

1.4 (b) rolling the compressed dough (I) through at least one of said surfaces (45)

The stages in which a predefined mass of dough in the shape of a loaf or ball is compressed between two surfaces of the Gastroteam machine, with the subsequent rolling out of the dough from its initial loaf shape to the desired circular pizza base shape, can be seen in the videos attached by the parties (see IMG_4982, IMG_4984 and IMG_4985) and are described in the *Pizza Former* user manual (see doc. 40, page 9). Below are some frames extracted from the aforementioned videos.

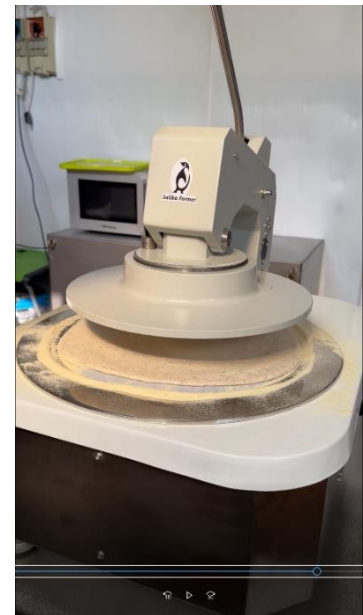

1.5 to generate periodic pressure waves within its mass;

As explained in the patent description, sub para. [0113] *"during operation of the forming machine 1, the conical rollers 21, 22, due to friction with the silicone intrados 45a of the membrane 45, roll on it and create in the contact area a wave extending diametrically with respect to the circular shape of the pizza base to be obtained, which moves periodically with a frequency equal to that of revolution around the vertical axis Y. The elasticity of the silicone membrane 45 and the tension thus created allow the dough I to penetrate the areas not occupied by the conical rollers 21, 22 during the compression phase exerted by the plate 50, thus forming waves that press on the dough and rotate it, working it in a uniform radial manner.*

The *Pizza Former* machine contains four rollers inside. The rotational movement of the conical rollers causes the pressure exerted on the membrane (and therefore on the dough) to oscillate periodically at each point or angular sector of the membrane (and therefore of the dough) between a maximum value (when the generatrix of one of the conical rollers is below that point, exerting maximum pressure) and a minimum value (when no generatrix of the conical rollers is at that point).

The pressure waves generated by the revolution of the conical rollers can be seen in the attached videos IMG_4982, IMG_4984 and IMG_4985.

1.6 wherein the pressure waves extend radially relative to the shape of the base to be made; The expression "*extend radially*" may refer to a static aspect whereby the pressure waves within the dough instantly have a shape that extends radially from the centre outwards along the diameter of the surface on which the dough mass to be worked is placed ("*relative to the shape of the base to be made*"). This feature is present in the *Pizza Former* machine because the pressure is exerted by the conical roller on the membrane (and therefore on the dough) above it for its entire radial extension along its axis, and therefore the periodic pressure wave generated will also have a radial extension along that axis.

The same expression can also refer to a dynamic aspect, whereby pressure waves follow a revolutionary motion around a central axis and at the same time also move radially from the centre towards the outside of the surface.

In the *Pizza Former* machine, the pressure waves also extend radially in a dynamic sense with respect to the shape of the base to be created, as can be seen in the video IMG_4985.

1.7 wherein the pressure waves rotate relative to the mass of dough (I);

1.8 wherein the pressure waves rotate in alternate cycles.

In the *Pizza Former* machine, the conical rollers first transmit the rotary motion of the waves they generate to the membrane and then to the dough in contact with it. The pressure waves rotate in alternating cycles due to the fact that the rotational motion of the conical rollers, which, as seen above, generate the pressure waves in the dough, occurs alternately in a clockwise and counterclockwise direction and is controlled by the motor in the *Pizza Former* machine (see videos IMG_4982 and IMG_5120).

2. Method according to claim 1, wherein the pressure waves are generated from below, through the bottom surface (45) whereon the mass of dough (I) has been laid.

The fact that the pressure waves are generated from below, through the bottom surface (the membrane) on which the dough mass is laid, and below which - as seen above - the conical rollers rotate, generating the pressure waves, is clearly visible in the attached videos IMG_4982 and IMG_5120.

3. Method according to claim 1 or 2, comprising the step of forming a swollen peripheral edge of the pizza base by expanding the dough radially beyond a predefined limit.

The upper plate of the Pizza Former machine has a flat profile in the centre and is slightly raised towards the outer edge of the crown, corresponding to a circular band. In addition, the lower membrane on which the dough rests also has a flat central profile and an outer circular band sloping outwards, resulting from the particular shape with rounded edges at the base of the conical rollers, as shown in the following images (see IMG_5006 and IMG_4976).



This creates an outer circular area where the dough is less compressed than in the central area and can therefore swell.

The enlarged peripheral edge (known as the 'cornicione') can be seen in the attached video IMG_4986 (from which the following image is taken).



4.1 Machine for implementing the method according to any one of the preceding claims, comprising;

There is no doubt that the *Pizza Former* machine is designed to shape food dough to make pizza bases and similar products, and that it allows all the steps listed in method claims 1, 2 and 3 of EP '454 to be implemented.

4.2 - a dough supporting diaphragm (45), which is at least partially deformable;

The *Pizza Former* machine includes a diaphragm - the flexible lower membrane fixed to the base) designed to support the dough to be processed, which is deformed by the conical rollers located below and in contact with it. The images below clearly show the presence of these elements in the Gastroteam machine.

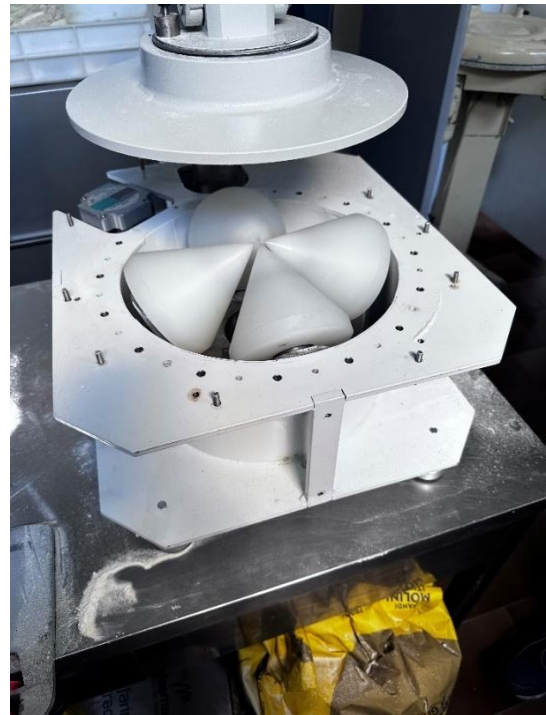

4.3 - a cover or plate (50) adapted to be moved between

4.4 an idle position, in which it is raised above the diaphragm (45), and

4.5 an operating position, in which it is set against the diaphragm (45), so as to compress a mass of dough (I) to be worked [...] laid thereon, and vice versa;

4.6 [in the usual loaf or bubble form,]

The upper plate of the *Pizza Former* machine corresponds to the "plate" mentioned in feature 4.3 of the patent. In the rest position, the upper plate is raised above the membrane on which the dough is placed in the shape of a loaf or bubble for processing.

In the operating position, the plate of the *Pizza Former* machine is lowered against the lower membrane, thereby compressing the dough placed on it, as shown in the following photographs.



4.7 - means (21, 22, 31, 33, 35) for deforming the diaphragm (45),

4.8 operating on that side of the latter which is opposite to the side whereon the dough (I) has been laid,

4.9 thereby causing pressure waves that extend radially relative to the shape of the base to be made;

4.10 wherein the means for deforming the diaphragm (45) comprise tapered rollers (21, 22) that operate by rolling on its intrados (45a);

4.11 wherein the rollers (21, 22) are adapted to make a motion of revolution about an axis (Y) substantially perpendicular to the diaphragm (45);

4.12 said motion of revolution being cyclically at time intervals clockwise and counterclockwise about said axis (Y).

The *Pizza Former* machine comprises means - the tapered rollers - located below and in contact with the lower deformable membrane, which are designed to deform said membrane by applying pressure to it.

The conical rollers in the *Pizza Former* machine that deform the membrane (or diaphragm) operate on the side of the membrane (the lower part) opposite to the side on which the dough is placed (the upper part).

For the radial extension of pressure waves, due to the revolution of the rollers on the central vertical axis, cyclically clockwise and counterclockwise at predetermined time intervals around the central vertical axis, please refer to the explanations already provided in relation to features 1.6, 1.7 and 1.8.

5. Machine according to claim 4, wherein the diaphragm (45) comprises at least one extrados layer (45b) in contact with the dough, made of food-grade low-friction plastic material. As can be seen in the video and photographic documentation attached by the plaintiffs, the membrane of the *Pizza Former* machine comprises an extrados layer, which is placed in contact with the dough and is made of low-friction plastic material suitable for food use (food-grade). The *Pizza Former* brochure states that 'the surface that comes into contact with the dough is made of food-grade, easy-to-clean materials' (see doc. 39c, page 4).

6. Machine according to claim 5, wherein the diaphragm (45) is a two-component or multi-component one, and comprises at least one said intrados layer (45a) made of a material different from that of the extrados layer (45b).

The reproduction of this feature is confirmed by the *Pizza Former* manual, which indicates the presence of a 'Lower membrane' and an 'Upper membrane' (see doc. 40, page 7), indicating the presence of two separate components ('two-component or multi-component').

7. Machine according to claims 5 or 6, wherein the material of the extrados layer (45b) comprises polytetrafluoroethylene (PTFE), while the material of the intrados layer (45a) comprises silicone or another material having a high coefficient of friction.

According to the parties, the appearance, consistency and mechanical behaviour of the extrados layer and the intrados layer of the membrane during operation confirm, respectively, that the extrados layer comprises polytetrafluoroethylene and that the intrados layer comprises silicone or, in any case, a material with a higher coefficient of friction than that of the extrados layer.

In the Court's view, the mere empirical observation of the behaviour of the materials used in the *Pizza Former* machine is not sufficient to prove their actual composition. The presence of polytetrafluoroethylene in the extrados layer and silicone (or other material with a different coefficient of friction) in the intrados layer has not been proven with the requisite degree of certainty.

8. Machine according to any one of claims 4 to 7, wherein the diaphragm (45) is fixed to a worktable (40) and its extrados surface (45b) protrudes from said table by a predefined difference in level (S).

The video and photographic documentation attached by the plaintiffs proves that the membrane of the *Pizza Former* machine is fixed to the machine's work surface, and its protruding surface extends beyond that work surface, as already noted above with regard to claim 3.

9. Machine according to any of claims 4 to 8, wherein the rollers (21, 22) are idle.

The tapered rollers of the *Pizza Former* machine are mounted idly on the turntable, which allows them to rotate. This feature can be seen in video IMG_5120. The tapered rollers rotate freely around their respective axes.

10. Machine according to any one of claims 4 to 9, wherein the tapered rollers (21, 22) comprise an edge (21b, 22b) rounded at the base.

The tapered rollers of the *Pizza Former* machine definitely include a rounded edge at the base. This feature allows for the effect of having a raised edge (known as a "cornicione", see *above* with regard to claim 3).

11. Machine according to any one of claims 4 to 10, wherein said intrados layer (45a) is made of or coated with silicone-based material, rubber-based material or another material having a high coefficient of friction.

As already noted with regard to claim 7, empirical observation of the behaviour of the materials used in the *Pizza Former* machine is not sufficient to prove their actual composition. The presence of polytetrafluoroethylene in the upper layer and silicone (or other material with a different coefficient of friction) in the lower layer has not been proven with the required degree of certainty.

12. Machine according to any one of claims 4 to 11, wherein the plate (50) comprises a face or surface (55) in contact with the dough, at least partly made of food-grade non-stick material.

As can be seen from the images reproduced above, the plate of the *Pizza Former* machine comprises a surface that comes into contact with the dough to be processed, made at least partly of a non-stick material suitable for food use. In fact, when the plate is lifted after the loaf has been rolled out, the dough remains on the membrane and does not stick to the contact surface of the plate itself.

13. Machine according to claim 12, wherein the contact surface (55) of the plate (50) has a profile that is substantially flat at the centre and slightly raised along a peripheral band (55a) near the outer edge.

It is sufficient to reiterate what has already been observed with regard to claim 3.

14. Machine according to any one of claims 4 to 13, wherein the plate (50) is supported by an articulated arm (3), which can be actuated manually and/or automatically in order to move the plate (50) into said operating and idle positions.

The images reproduced above show that the plate of the *Pizza Former* machine is supported by an articulated arm, which can be operated to move the plate between the operating and non-operating positions.

15. Machine according to claim 14, wherein the articulated arm (3) comprises an articulated quadrilateral structure (301, 302, 303, 510, 511, 520, 521) adapted to hold the plate (50) in a condition substantially parallel to the diaphragm (45) during the translations between said operating and idle positions, and vice versa.

The articulated arm of the *Pizza Former* machine keeps the plate in a condition parallel or substantially parallel to the membrane (diaphragm) during movements between the operating position and the idle position, and vice versa (see video IMG_4984).

Regarding the presence of the articulated quadrilateral structure, the following is reported by the technician appointed by the plaintiffs (see doc. 47, page 9): "*Describing the articulated arm in greater detail, it comprises two lateral semi-arms made in one piece. The ends of the semi-arms are hinged to the plate and the column respectively (see figure 2). The structure of the articulated arm also includes a core interposed between the side semi-arms, the ends of which are respectively coupled to two other hinge pins (see attached video IMG_5134). The four hinges, the semi-arms and the core define an articulated quadrilateral.*"

16. Machine according to claims 14 or 15, wherein the plate (50) comprises a fitting (53) for connecting to the arm (3), and a crown (500) adjustably associated with the fitting (53).

17. Machine according to claim 16, wherein the crown (500) is associated with the fitting (53) by means of a threaded connection (502, 505), which allows for fine adjustment of the distance between the bottom face (55) of the plate (50) and the diaphragm (45) when the plate is in the lowered operating condition.

The plate of the *Pizza Former* machine comprises a fitting for connection to the arm and a crown associated with the fitting in an adjustable manner. In particular, by rotating the crown with respect to the fitting, it is possible to adjust the position of the plate with respect to

the end of the arm (in order to vary the distance from the membrane and therefore the thickness of the pizza base resulting from the processing of the dough) (see doc. 47, page 6; IMG_5019, IMG_5021, IMG_5022).

18. Machine according to any one of claims 4 to 17, wherein the plate (50) is supported by an articulated arm (3), which can be actuated manually and/or automatically in order to move the plate (50) into said operating and idle positions, comprising a handle (54) or the like for actuating the articulated arm (3), positioned in such a way that the articulated arm (3) will substantially form a second-order lever with respect to a dough (I) to be worked.

Reference is made to everything already stated with reference to claims 14 and 15.

In light of all the above considerations, the Court finds that the *Pizza Former* machine literally reproduces all the features indicated in the claims of EP' 454, with the sole exception of claims 7 and 11, in respect of which a sufficient degree of certainty has not been provided as to the actual use of certain types of materials.

9. Infringing conduct of the defendants.

The plaintiffs have provided full proof of the actual direct infringement of the EP'454 patent by Gastroteam and Marciuliano, pursuant to Article 25.1(a) UPCA. There is, in fact, multiple documentary evidence (i) of the manufacture in Sweden, (ii) of the offer for sale and (iii) of the placing on the market in Italy and in all other Contracting Member States of the *Pizza Former* machine.

In particular, it has been proven that Gastroteam offered the *Pizza Former* machine for sale through the websites *gastroteam.se* and *salibaequipment.com*, as well as through various social media platforms. All of these online promotional and commercial channels can be uniquely traced back to the Swedish company that is the defendant in this case (see doc. 17 et seq. plaintiffs).

On the website *gastroteam.se*, it is possible to purchase the *Pizza Former* with delivery only in Sweden and Denmark (as well as Finland and Norway, which are not relevant in this proceeding).

On the website *salibaequipment.com*, it is possible to purchase the *Pizza Former* machine with delivery worldwide, including Italy and the other 17 countries that have ratified the Agreement on the Unified Patent Court to date.

The following are also duly documented: an offer from Gastroteam with a sales price quotation dated 23 October 2024 addressed to a potential customer based in France (doc. 27); the issue on 10 April 2022 of an invoice from Gastroteam for the sale of a *Piz-zaform/pizzapress* machine to a Swedish customer (doc. 29). In addition to these commercial documents, there are numerous videos published by Gastroteam on its social network profiles

which it expressly admits to having completed several sales of *Pizza Formers*, with delivery in Italy (see doc. 35 et seq., 55) or to having manufactured the machine directly (see doc. 51 and 55).

As regards Marciuliano's position, there is evidence (i) of the offer for sale of the machine *Pizza Former* via its WhatsApp business channel (see doc. 32), (ii) the forwarding on 10.6 - 2.7.2024 of quotations for the sale and transport of a *Pizza Former* machine to a potential customer based in Italy, with subsequent completion of the deal (doc. 33a-d) and (iii) the preparation of a commercial brochure for the product in Italian, specifically intended for customers in that country (see doc. 39a).

10. Assessment of patent infringement and subsequent rulings.

In light of all the above considerations, the Court finds and declares that Gastro-team and Marciuliano are liable for infringement of patent EP'454, in accordance with the provisions of Article 64.2(a) UPCA.

The seriousness of the infringement justifies the issuance of an injunction against both defendants to prohibit the continuation of the unlawful conduct, based on the combined provisions of Articles 25 and 63 UPCA. The Court considers it appropriate to emphasise that the *Pizza Former* machine manufactured and sold by the defendants is a complete replacement for the *Pizza-rella* machine, manufactured and marketed by the plaintiffs on the basis of the patent teachings. This means that every product sold by the defendants deprives the plaintiffs of the sale of a corresponding unit of the patented machine.

The conduct of Gastroteam and Marciuliano is therefore likely to cause a direct, immediate and difficult-to-reverse erosion of market share to the detriment of the parties, such as to justify the adoption of the injunction as requested.

As already noted above, EP'454 is a European patent with unitary effect, registered on 2 September 2024 (see doc. 44 plaintiffs). It follows that the injunction order is effective throughout the territory of all current Contracting Member States, in accordance with the provisions of Articles 3 and 5 of EU Regulation No. 1257/2012.

For the same reasons - and therefore reiterating the assessment of the objective seriousness of the infringement found - the Court also considers the adoption of an order to withdraw the counterfeit products from the commercial circuits and their subsequent destruction, to be carried out at the expense of the defendants within 30 days of notification of this decision, as provided for in Articles 64.2(b)(e) and 64.3 UPCA, to be entirely proportionate and justified.

The request made by the plaintiffs pursuant to the combined provisions of Article 67 UPCA and Rule 191 RoP to obtain information relating to:

- a) the origin and distribution channels of counterfeit products;
- b) the quantities of counterfeit products produced, manufactured, supplied, received or ordered, as well as the price obtained from their sale;
- c) the identity of any third parties involved in the production or distribution of counterfeit products.

The right to obtain information is instrumental in initiating any subsequent proceedings on the merits for the settlement of damages, as it allows for specific questions to be asked, with the quantification of compensation claims strictly based on verifiable and verified documentary data. The defendants retain the right to request the protection of any confidential information contained in the documents whose disclosure is ordered. This is without prejudice to any future assessment by the Court regarding the protection of confidential information, in order to ensure the necessary balance with the protection of the right of defence.

Finally, the Court orders that this decision be published in accordance with Article 80 of the UPCA, at the expense of Gastroteam, in the manner specified in the operative part, in addition to the usual publication of decisions of the Unified Patent Court in a dedicated section of the institutional website. The need to promote the dissemination of the contents of this judgment is linked to the repeatedly highlighted seriousness of the infringement of the patent holder's exclusive rights.

Pursuant to the combined provisions of Articles 63.2 and 82.4 UPCA and Rule 354.3 RoP, the decisions of the Court may provide for the payment of a financial penalty, payable to the Court itself, in the event that a party fails to comply with the requirements contained in the decision or in the event of failure to comply with an injunction. The amount of such a penalty shall be proportionate to the importance of the requirement laid down in the decision.

The necessary compliance with the principle of proportionality is further provided for in Article 3 of Directive 2004/48/EC and Article 43 of the TRIPS Agreement. This assessment must be based on all the evidence gathered in the specific case (on the principle of proportionality in general, see EU Court of Justice C-205/20; see UPC CFI No. 230/2023, 30.1.2024, LD Paris; UPC CFI No. 241/2023, 4.11.2024, LD Milan).

In the present case, taking into account the market price of the *Pizzaformer* product, which is approximately 5,500 euros (see doc. 12a plaintiffs), the Court considers it appropriate to impose on Gastroteam and

Marciuliano to pay a penalty of €11,000 for each individual product manufactured, offered or placed on the market by each of the defendants in violation of the injunction. It also orders each of the defendants to pay an additional penalty of €5,000 for each day of delay in complying with the obligations imposed by this decision.

This decision is immediately enforceable in all Contracting Member States, pursuant to Article 82.1 UPCA and Rule 355.4 RoP, without further conditions, from the date of its notification. In particular, it is not considered necessary to order the suspension of enforcement or to make enforcement conditional upon the prior payment of a security deposit by the plaintiffs. In any case, the plaintiffs may proceed with the necessary enforcement activities in compliance with the conditions set out in Rule 118.8 RoP.

The respondents are required to compensate Morello, as the patent holder, and Morello Italia, as the licensee, for the damages caused, in accordance with the provisions of Article 68 UPCA. The precise quantification of these damages is left to a possible subsequent judgment on the merits, pursuant to Rules 125 et seq. RoP.

The claim made by the plaintiffs pursuant to Rule 119 RoP for an interim award of damages is upheld. The provisional payment is settled taking into account the value of the present dispute, equal to 500,000 euros, as declared by the plaintiffs for the purposes of paying court fees, and the related ceiling on recoverable legal costs for the future compensation proceedings of equal value, a ceiling of €56,000, as established by *the Scale of ceilings for recoverable costs* adopted by the Administrative Committee on 24 April 2023, in implementation of rule 152.2 RoP.

In the present case, it is considered fair to recognise the provisional amount requested in a different measure for each of the two defendants, taking into account the different territorial extent of their respective infringing conduct - Marciuliano operates only in Italy - and the objectively greater seriousness of Gastroteam's conduct.

The Court therefore awards provisional damages in the amount of €46,000 against Gastroteam and €10,000 against Marciuliano.

11. Value of the dispute and legal costs

The plaintiffs have declared a value of the dispute of €500,000. There are no factual elements that would allow this quantification to be questioned or modified in any way, and it is therefore accepted by the Court, also for the purposes of quantifying the recoverable legal costs.

Pursuant to Article 69.1 of the UPCA, the defendants, as wholly unsuccessful parties, are required to pay the legal costs incurred by the plaintiffs, up to a maximum limit determined in accordance with the Rules of Procedure.

According to *the Scale of ceilings for recoverable costs* adopted by the Administrative Committee on 24 April 2023, implementing Rule 152.2 RoP, for cases with a value of up to €500,000, there is a maximum limit of €56,000.

Therefore, in the present case, the maximum limit for recoverable litigation costs for the patent infringement action is set at €56,000 in total.

The successful parties will be entitled to reimbursement of legal costs in accordance with rules 150 et seq. RoP.

DECISION

The Unified Patent Court, Court of First Instance, Local Division of Milan:

- 1) finds and declares that Gastroteam Abbe AB and Salvatore Marciuliano, owner of the sole proprietorship Marciuliano Attrezzature, have infringed European patent with unitary effect No. EP3691454, owned by Morello Forni s.a.s. di Morello Marco & C.,
 - in the case of Gastroteam Abbe AB, by manufacturing, offering for sale and placing on the market in all Contracting Member States
 - as regards Salvatore Marciuliano, owner of the sole proprietorship Marciuliano Attrezzature, by offering for sale and placing on the market in Italy of the machine with the trade name *Pizza Former*, or however named, as it has the characteristics indicated in claims 1, 2, 3, 4, 5, 6, 8, 9, 10, 12, 13, 14, 15, 16, 17 and 18 of EP3691454;
- 2) prohibits Gastroteam Abbe AB and Salvatore Marciuliano, owner of the sole proprietorship Marciuliano Attrezzature, from manufacturing, offering for sale and placing on the market in Austria, Belgium, Bulgaria, Denmark, Estonia, Finland, France, Germany, Italy, Latvia, Lithuania, Luxembourg, Malta, the Netherlands, Portugal, Romania, Slovenia and Sweden of the machine with the trade name *Pizza Former* - or however named - which reproduces in whole or in part the characteristics indicated in the claims of EP3691454;
- 3) orders Gastroteam Abbe AB and Salvatore Marciuliano, owner of the sole proprietorship Marciuliano Attrezzature, to proceed at their own expense with the withdrawal of the counterfeit products from commercial channels and their subsequent destruction within thirty days from the date of notification of an enforceable copy of this decision, subject to compliance with all the conditions set out in Rule 118.8 RoP, with the defendants further obliged to provide the plaintiffs with a copy of all product recall letters;

- 4) orders Gastroteam Abbe AB and Salvatore Marciuliano, owner of the sole proprietorship Marciuliano Attrezzature, to provide the parties, in digital format, within thirty days of notification of an enforceable copy of this decision, subject to compliance with all the conditions set out in Rule 118.8 RoP, all information relating to:
 - a) the origin and distribution channels of the *Pizza Former* machine;
 - b) the quantities produced, manufactured, supplied, received or ordered of the machine in question, as well as the turnover generated by its sale; and
 - c) the identity and details of any third parties involved in the production or distribution of the counterfeit machine in question, and this by filing, in particular:
 - (i) invoices, transport and delivery documents, journals, inventory books, VAT registers, warehouse loading and unloading registers, and any other document useful for indicating the quantities sold - broken down by period (by month and year) - the prices of the goods sold and the names of the models, as well as the names and addresses of the recipients of all commercial offers for the products sold;
 - (ii) invoices, customs and import documents, T1 declarations for external Community transit, T2 declarations for internal customs transit, INTRASTAT forms (summary of intra-Community trade in goods) for all products sold and purchased;
 - (iii) documents relating to all advertising and promotional activities carried out, broken down by means used, distribution period and distribution territory;
 - (iv) invoices, transport and delivery documents and any other document relating to costs incurred, broken down by individual cost factors, and profits made, so as to clarify all the elements necessary for calculating the profits obtained;
all accompanied by explanatory notes to allow for a more immediate understanding of the data transmitted;
- 5) orders Gastroteam Abbe AB to include the following text on the homepage of its websites gastroteam.se and salibaequipment.com within thirty days of notification of an enforceable copy of this decision, subject to compliance with all the conditions set out in Rule 118.8 RoP, for a period of one continuous month, without additional or alternative text and with a direct link to the full text of the decision, in an easily legible and immediately visible box, positioned at the top of the homepage immediately below the browser address bar, covering at least 10% of the homepage surface area: "*By decision of 19 November 2025, as final outcome of the proceedings UPC CFI no. 802/2024, the Unified Patent Court, Court of First Instance, Milan Local Division, ruled that Gastroteam Abbe AB has infringed the patent EP 3691454 owned by the Italian company Morello Forni s.a.s. di Morello Marco & C. by*

manufacturing, offering and placing on the market, including through this website and in the territories of Austria, Belgium, Bulgaria, Denmark, Estonia, Finland, France, Germany, Italy, Latvia, Lithuania, Luxembourg, Malta, the Netherlands, Portugal, Romania, Slovenia and Sweden, an apparatus for shaping pizza dough named Pizza Former or Pizza-press or Pizzaform. Gastroteam Abbe AB has been ordered to refrain from all these unlawful conducts and therefore will no longer market these products.

- 6) sets a penalty of €11,000 to be paid to the Court for each individual product manufactured, offered or placed on the market by each of the defendants in violation of the injunction referred to in point 2) and a penalty of €5,000.00 for each day of delay in the execution of the additional obligations imposed by this decision in points 3), 4) and 5);
- 7) orders Gastroteam Abbe AB to pay Morello Forni s.a.s. di Morello Marco & C. and Morello Forni Italia s.r.l. the sum of €46,000.00 as provisional compensation for the damage eligible for compensation;
- 8) orders Salvatore Marciuliano, owner of the sole proprietorship Marciuliano Attrezzature, to pay Morello Forni s.a.s. di Morello Marco & C. and Morello Forni Italia s.r.l. the sum of €10,000.00 as provisional compensation for the damage eligible for compensation;
- 9) Gastroteam Abbe AB and Salvatore Marciuliano, owner of the sole proprietorship Marciuliano Attrezzature, are required to reimburse the plaintiffs' legal costs, to be settled in separate proceedings pursuant to Rule 151 et seq. RoP;
- 10) The value of this case is set at €500,000.00. Milan, 19 November 2025.

Pierluigi Perrotti
Presiding Judge and Judge Rapporteur

**Pierluigi
Perrotti** Digitally signed by
Pierluigi Perrotti Date:
18 November 2025
10:46:44 +01'00'

Alima Zana
judge qualified in legal matters

**Alima
ZANA** Digitally signed by Alima
ZANA
Date: 17 November 2025
22:53:40

Samuel Granata
legally qualified judge

**Samuel Rocco
M Granata** Digitally signed by
Samuel Rocco M Granata
Date: 17 November 2025
19:35:23 +01'00'

for the Deputy Registrar

**FERRARI
MANUELA** Digitally signed by
FERRARI MANUELA
Date: 18 November 2025
11:45:58

INFORMATION ON THE APPEAL

Any party that is unsuccessful, in whole or in part, may appeal against this decision to the Court of Appeal within two months of the date of notification of this decision (Art. 73 UPCA, Rules 220.1(a), 224.1(a) RoP).

INFORMATION ON ENFORCEMENT

A certified copy of the enforceable decision will be issued by the Deputy Registrar upon request by the party seeking enforcement (Art. 82 UPCA, Art. 37.2 UPCS, Rules 118.8, 354, 355.4 RoP, Rule 69 RegR).